

Author: David Steyh  
© 2011 *All Rights reserved.*

This Revelation teaching may be freely distributed with some restrictions.

Sectional files must stay sectioned; and cannot be combined.

All distribution must be free of charge.

A *link* to my controlling webpage [www.revelationdisclosed.com](http://www.revelationdisclosed.com) must be posted on the same webpage where any sectional files or text is posted.

You are also allowed to the html text of this teaching; as long as you do not edit or change it; and as long as you do not combine various sections or chapters.

Again - if you elect to post text or sectional chapters - you are *required* to provide a prominent *Link* back to my controlling webpage. [www.revelationdisclosed.com](http://www.revelationdisclosed.com)

This teaching is freely given for the edification of Jesus and His church. No portion of it may be changed under any circumstances. Feel free to discuss, criticize, etc.

If you elect to post a sectional file; you must post ALL sectional files for free download. (Prevents stuff from being taken out of context.)

If you post a section of html text; you are required to post ALL html sectional text files.

I use the NIV in this teaching extensively. Consequently - if you post this teaching in html text format on your website - you should also provide a visible *permissions* notice on your site. Such as is found at the front of every sectional file; or in the html text; and on the [revelationdisclosed](http://www.revelationdisclosed.com) website itself.

You are free to copy/paste (this Revelation Teaching *only*) from our website to your own.

Please feel free to download & print this teaching on Revelation. Tell people about the teaching. Encourage people to just READ the book of Revelation over and over and over again. To develop your ear to hear the wonderful Spirit of God; our personal teacher and instructor; the Holy Spirit!

It is also STRONGLY suggested and encouraged that you read this teaching on Revelation in *Order* of sections and chapters . . . number *One* first; followed by *Two*, next three; etc. If you just jump to a particular section; you will probably become confused as to why I make certain statements. If you have not as yet read the 'about the author' or my '*preface*' page - please do so! Really; this will help out quite a bit. They are found in *section One*.

THANKS! And may your ears and eyes be opened to understanding this glorious prophecy.

*David Steyh*

## *Revelation Disclosed*

Author: David Steyh

Location: Seattle, WA; USA

© 2011 *All Rights reserved.*

All scripture quotations, unless otherwise indicated, are taken from the Holy Bible, International Version®, NIV®. Copyright ©1973, 1978, 1984, 2011 by Biblica, Inc.™ Used by permission of Zondervan. All rights reserved worldwide.

[www.zondervan.com](http://www.zondervan.com)

The “NIV” and “New International Version” are trademarks registered in the United States Patent and Trademark Office by Biblica, Inc.™

{Author’s note: This commentary does **NOT** use any scriptures from the *2011 Biblica, Inc.* version of the NIV® bible. It quotes only from the older NIV® version with the following *obsolete* copyright notice:

*Scripture taken from the HOLY BIBLE, NEW INTERNATIONAL VERSION ®. Copyright ©1973, 1978, 1984 by International Bible Society. Used by permission of Zondervan. All rights reserved.*}

Scripture quotations marked (AMP) are taken from the Amplified Bible, Copyright © 1954, 1958, 1962, 1964, 1965, 1987 by The Lockman Foundation. Used by permission.

Scripture quotations marked “KJV” are taken from the King James Version - public domain

Scripture quotations marked “NKJV™” are taken from the New King James Version®. Copyright © 1982 by Thomas Nelson, Inc. Used by permission. All rights reserved.

The Bible text designated (TLB) is from THE LIVING BIBLE Copyright © 1971. Used by permission of Tyndale House Publishers, Inc., Wheaton, IL 60189. All rights reserved.

Scripture quotations marked “NASB” are taken from the New American Standard Bible®, Copyright © 1960, 1962, 1963, 1968, 1971, 1972, 1973, 1975, 1977, 1995 by The Lockman Foundation Used by permission." ([www.Lockman.org](http://www.Lockman.org))

Scripture quotations marked “RSV” are from Revised Standard Version of the Bible, copyright © 1946, 1952, and 1971 National Council of the Churches of Christ in the United States of America. Used by permission. All rights reserved.

Scripture quotations marked “NRSV” are from New Revised Standard Version Bible, copyright © 1989 National Council of the Churches of Christ in the United States of America. Used by permission. All rights reserved.

Scripture quotations marked “YLT” are from YOUNG’S LITERAL TRANSLATION By ROBERT YOUNG Originally published in 1862, Edinburgh. Revised Edition 1887. Public Domain

Scripture quotations marked “DARBY” are from THE DARBY BIBLE The text of: THE HOLY SCRIPTURES A New Translation from the Original Languages By John Nelson Darby first published in 1890. Public Domain.

All Greek/Hebrew definitions (*unless otherwise noted*) are taken from *The NIV Exhaustive Concordance* by Edward W. Goodrick & John R. Kohlenberger III © 1990 by The Zondervan Corporation. ISBN 0-310-436970-7

\*\*\*\*\*

In 2002; Zondervan published a really cool software program called *Pradis*. (Discontinued in 2009) The author purchased the Pradis Bible Study Library software suite titled: Scholar’s Edition. This program allows you to directly search on Greek/Hebrew definitions determined by Goodrick & Kohlenberger III. It also allows me to copy/paste scripture. The author has purchased (and uses) the physical *Bible* and *Exhaustive Concordance* referenced above. However, for this commentary - he is using the Pradis software for ease and convenience. The Pradis suite; had (for me) a steep learning curve; but I wish it had not been discontinued. The resources available in it - are phenomenal.

I have also (quite some time back) purchased *PC STUDY BIBLE* software; and resources in this software suite are also sometimes used in this commentary. When that is done - it is always referenced at the point of use.

## Section 2 (Main Chapters discussed: 6 - 9)

(Chapter 5)

*Then I saw in the right hand of him who sat on the throne a scroll with writing on both sides and sealed with seven seals. And I saw a mighty angel proclaiming in a loud voice, "Who is worthy to break the seals and open the scroll?" But no one in heaven or on earth or under the earth could open the scroll or even look inside it. I wept and wept because no one was found who was worthy to open the scroll or look inside. Then one of the elders said to me, "Do not weep! See, the **Lion of the tribe of Judah**, the Root of David, has triumphed. He is able to open the scroll and its seven seals." Then I saw a **Lamb**, looking as if it had been **slain**, standing in the **center** of the **throne**, encircled by the four living creatures and the elders. He had **seven horns** and **seven eyes**, which are the **seven spirits of God** sent out into all the earth.*  
(Rev 5:1 - 6)

The above verses are mostly self explanatory. John now sees a scroll. The scroll is important. Some believe that this scroll represents a type of *title deed*. Adam was given original authority over the Earth, and all creatures on this earth. He, and we - were supposed to be rulers and guardians over God's beautiful creation. However, when Adam sinned - authority for the Earth and God's creation - was given to Satan. Jesus though - provided thru his Blood - and the shedding of His sinless life; forgiveness and redemption for man - back to God.

I tend to believe that those who think the scroll is a type of *title deed* - are correct. But again - it doesn't really matter. It does not change the focus and direction of this prophecy.

The above scriptures are quite clear that this scroll is sealed up - and NO ONE in Heaven, on Earth, or under the earth is WORTHY to open this scroll. **NO ONE!!** John weeps, he is so overcome with emotion that NO ONE is worthy ANYWHERE to be able to open this scroll! Then, he is told *not* to weep, because the **Lion** of the tribe of Judah, the **Root** of David, has triumphed! Jesus is WORTHY. Jesus has accomplished many, many things for us. He gives us gifts freely, and redeems us to God. Jesus, himself - is looking for a WIFE. A *wife*. A marriage covenant. Jesus is seeking a Bride for himself. But with all that Jesus has done; with all that He FREELY gives to me; I and anyone else - will never be worthy to open this scroll. ONLY Jesus is *Worthy!* Only Him, the great Alpha and the Omega, the Lamb who was slain... ONLY Jesus is worthy to open this special scroll!

So Jesus takes the scroll from the right hand of the Father, and then ALL of Heaven - and ALL of earth, and ALL of everyone under the earth - **EVERYONE WORSHIPS JESUS!**

*And they sang a new song: "You are **worthy** to take the **scroll** and to **open its seals**, because you were **slain**, and with **your blood** you purchased men for God from every tribe and language and people and nation. You have made them to be **a kingdom** and **priests to serve our God**, and **they will reign** on the earth." Then I looked and heard the voice of **many angels**, numbering **thousands upon thousands**, and ten thousand **times ten thousand**. They encircled the throne and the living creatures and the elders. In a loud voice they sang: "**Worthy is the Lamb**, who was slain, to **receive power** and **wealth** and wisdom and strength and **honor and glory and praise!**" Then I heard **every creature** in **heaven and on earth** and **under the earth** and on **the sea**, and **all that is in them**, singing: "**To him who sits on the throne** and to **the Lamb** be **praise and honor and glory and power, for ever and ever!**" The four living creatures said, "Amen," and the elders fell down and **worshiped**." (Rev 5:9 - 14)*

(Chapter 6)

1<sup>st</sup> Seal.

*I watched as the Lamb opened the first of the seven seals. Then I heard one of the four living creatures say in a voice like thunder, “Come!” I looked, and there before me was a white horse! Its rider held a bow, and he was given a crown, and he rode out as a conqueror bent on conquest.* (Rev 6:1 - 2)

Some state the above verse is Jesus Christ, on a white horse. Some state the above is Christianity - going throughout the world. Except for this seal - All of the results of the *other* five seals - are clearly stated in Chapter 6. We have five seals - All of which produce ‘undesirable’ results. The above is hardly Jesus, or Christianity. These two schools of thought - do not flow with the rest of the prophecy.

The first seal calls out a white horse. The color white carries some easily suggested meanings. The colors of the horses mentioned in the other three seals - are not so easily discerned. But since white can be used to signify *righteousness*; and or false religion . . .

*And no wonder, for Satan himself masquerades μετασχηματίζεται ((act) to transform, change (the form); (mid) to masquerade, disguise (oneself)) as an angel of light.* (2 Corinthians 11:14)

*I counsel you to buy from me gold refined in the fire, so you can become rich; and White clothes to wear, so you can cover your shameful nakedness . . .* (Rev 3:18)

*Yet you have a few people in Sardis who have not soiled their clothes. They will walk with me, dressed in white, for they are worthy.* (Rev 3:4)

The white λευκός (*white; bright, gleaming*) horse is signifying false religion. This is a promotion of a false religion. A religion which will conquer the world. It is a religion bent on conquest; and it will conquer. It will succeed. It is ordained by God that this religion will go out to deceive and conquer. It will do so. The religion is Islam.

“ ‘By what means?’ the LORD asked. “ ‘I will go out and be a lying spirit in the mouths of all his prophets,’ he said. “ ‘You will succeed in enticing him,’ said the LORD. ‘Go and do it.’ (1Kings 22:22)

*The LORD said to Moses, “When you return to Egypt, see that you perform before Pharaoh all the wonders I have given you the power to do. But I will harden his heart so that he will not let the people go.* (Exodus 4:21)

*But I will harden Pharaoh’s heart, and though I multiply my miraculous signs . . .* (Exodus 7:3)

In these end times - many deceptions, and powerful wonders are going to be performed. God’s word stands. He has made known thru scripture - and his special prophecy Revelation - what is going to happen. God is calling us to stand firm! (*To him who overcomes; He who overcomes* (R2:7; 21:7)) To remain in Him. The two witnesses - who stand before the Lord of the earth; and perform mighty miracles - will testify against the anti-Christ, and all surrounding events . . . People’s hearts even today are hard - and they are going to become harder and more wicked - and they will not repent. This first seal being opened - is the start of all of this great and massive deception; and tribulation and trouble on the earth - as has never before been experienced.

because those will be days of *distress* unequalled from the beginning, when God created the world, until now and *never to be equaled again*. (Mark 13:19)

Let him who does wrong continue to do wrong; let him who is *vile continue to be vile* . . . (Rev 22:11)

The rider or controller of the horse *already* possesses a *Bow*. Here, he is *given* a *crown*. The crown signifies victory, power, authority, and reigning over the earth. The bow is a weapon of warfare.

Islam was founded by the ‘prophet’ Mohammed. Muslims believe and are taught that Mohammed was directly descended from Abraham. Islam teaches that the biblical account of Isaac going up to the mountain top - where Abraham’s faith was tested is incorrect and false. Islam teaches that it was Ishmael who Abraham went to the mountain with . . .

Now, what does scripture teach with regards to Ishmael?

*He will be a wild donkey of a man; his hand will be against everyone and everyone’s hand against him, and he will live in hostility toward all his brothers.*” (Genesis 16:12)

*And as for Ishmael, I have heard you: I will surely bless him; I will make him fruitful and will greatly increase his numbers. He will be the father of twelve rulers, and I will make him into a great nation.* (Genesis 17:20)

*God was with the boy as he grew up. He lived in the desert and became an archer.* (Genesis 21:20)

Now what is an *archer*?? An *archer* is a *Warrior*. Someone who was victorious using the bow. The NIV Bible Dictionary states:

ARCHERS. Bowmen, hunters, or *warriors* with bow and arrows. Ishmael is the first man so named in the Bible. Joseph is represented as victor in a *battle* of archery . . . Archery plays a part in the crisis in the relations of David and Jonathon. Philistine archers mortally wounded Saul. The sons of Ulam, Benjamites, “were *brave warriors* who could handle the bow.” Josiah was killed by archers. Job compares his troubles to being surrounded by archers . . . Light - armed, mobile, effective at a distance, archers were valuable in any *army*, and their skill was no less useful in hunting. (Pradis; 1987 by Zondervan; Rel 03.17.03)

It could be said, from the above definition - that since archers were invaluable to an army - that any scripture referencing conquering - would by necessity have need of archers. So, an illustrative figure with a *Bow* - is hardly conclusive evidence. Which is true.

However - I have been reading and listening to the prophecy which is Revelation - virtually every day - since early 2004. The first seal listed in chapter 6 - was on my mind and heart for quite some time. It did not seem to flow that this was Jesus, or Christianity. Two years of waiting on the Lord on the above seal - and it was finally revealed that this was Islam. And, even if it is not Islam; if I am wrong - it does not change the flow and focus of this prophecy. We need to be careful not to become all wrapped up over very small points, and arguing about minutiae which do not matter. Even if this *is* Jesus (**NOT!!**) - it still wouldn’t change the flow of the rest of this prophecy. It doesn’t fit for it to be Jesus - but that does not significantly change the flow of events which constitute Revelation.

The first seal is *Islam* conquering the world. But what if it *isn’t* Islam? Well, it would still be a false

religion sent out to deceive. Revelation reveals that MILLIONS and MILLIONS of people will go to Hell. The lake of fire. They will be utterly condemned because of their worship of Satan. In these days which we are living - Satan is going to perform miraculous signs and wonders - and deceive the entire earth. He is going to be using false religion as one of his tools to accomplish this deception. And since the great deceiver is 'behind' every false religion - then in a significant way - it could be stated that Satan is the one going out on a white horse to conquer. So it is possible - that this is Satan himself - *directly* going out to conquer . . .

Now, what is the history of Islam?

[Adherence to Islam is a **global** phenomenon: Muslims predominate in some 30 to 40 countries, from the Atlantic to the Pacific and along a belt that stretches across northern Africa into Central Asia and south to the northern regions of the Indian subcontinent. Arabs account for fewer than one-fifth of all Muslims, more than half of whom live east of Karachi, Pak. Despite the absence of large - scale Islamic political entities, the Islamic faith continues to expand, by some estimates faster than any other major religion. (\*1)

A major world religion belonging to the Semitic family; it was promulgated by the Prophet Muhammad in Arabia in the 7th century AD. The Arabic term *islam*, literally "**surrender**," illuminates the fundamental religious idea of Islam - that the believer (called a Muslim, from the active participle of *islam*) accepts "**surrender to the will of Allah** (Arabic: God)." Allah is viewed as the sole God - creator, sustainer, and restorer of the world. The will of Allah, to which **man must submit**, is made known through the sacred scriptures, the Qur'an (Koran), which Allah revealed to his messenger, Muhammad. In Islam Muhammad is considered the **last of a series of prophets** (including Adam, Noah, Jesus, and others), and his message simultaneously **consummates and abrogates** the "revelations" attributed to earlier prophets. Retaining its emphasis on an uncompromising monotheism and a strict adherence to certain essential religious practices, the religion taught by Muhammad to a small group of followers **spread rapidly** through the Middle East to Africa, Europe, the Indian subcontinent, the Malay Peninsula, and China. Although many sectarian movements have arisen within Islam, **all Muslims are bound** by a common **faith** and a **sense of belonging to a single community**. (\*2)

In AD 622, when the Prophet fled to Medina, his preaching was soon accepted, and the **community-state of Islam emerged**. During this early period, **Islam acquired its characteristic ethos** as a religion uniting in itself both the spiritual and temporal aspects of life and **seeking to regulate** not only the individual's relationship to God (through his conscience) but **human relationships in a social setting as well . . .**

This **dual religious and social character of Islam**, expressing itself in one way as a religious community commissioned by God to bring **its own value system** to the **world** through the **jihad** ("holy war" or "holy struggle"), explains the astonishing success of the early generations of Muslims. Within a century after the Prophet's death in AD 632, they had brought a large part of the globe - from Spain across Central Asia to India - under a new Arab Muslim empire.

The period of **Islamic conquests and empire building** marks the first phase of the expansion of Islam as a religion. Islam's essential egalitarianism within the community of the faithful and its **official discrimination against** the followers of **other religions** won rapid converts. Jews and Christians were assigned a special status as communities possessing scriptures and called the "people of the Book" (*ahl al-kitab*) and, therefore, were allowed religious autonomy. They were, however, required to pay a per capita tax called *jizyah*, as opposed to pagans, who were required to **either accept Islam or die . . .** (\*3)



The beginnings of theology in the Islamic tradition in the second half of the 7th century are not easily distinguishable from the beginnings of a number of other disciplines - Arabic philology, Qur'anic interpretation, the collection of the sayings and deeds of the prophet Muhammad (Hadith), jurisprudence, and historiography. Together with these other disciplines, Islamic theology is concerned with ascertaining the facts and context of the Islamic revelation and with understanding **its meaning and implications** as to what **Muslims should believe and do** after the revelation had ceased and the Islamic community had to chart its own way . . . (\*4)

The word *islam* is used repeatedly in the Qur'an, the Islamic scripture, in the sense of “**surrender** to the will of Allah (God).” For Muslims, as adherents of Islam are called, the **Qur'an** is the Word of God, confirming and consummating earlier revealed books and **thereby replacing them**. The Word's instrument or agent of revelation is the Prophet Muhammad, the last and most perfect of a series of messengers of God to mankind - from Adam through Abraham to Moses and **Jesus**, the Christian claims for whose **divinity are strongly rejected** . . . (\*5)

The five pillars:

The first pillar is the profession of faith: “There is no God but God, and Muhammad is the prophet of God.” . . .

The second pillar consists of five daily congregational prayers. . . .

The third pillar is the obligatory tax called *zakat* (“purification,” indicating that such a payment makes the rest of one's wealth religiously and legally pure) . . .

Fasting during the month of Ramadan (ninth month of the Muslim lunar calendar), laid down in the Qur'an (2:183–185), is the fourth pillar of the faith . . .

The fifth pillar is the **annual pilgrimage (*hajj*) to Mecca** prescribed for every Muslim **once in a lifetime** - “provided one can afford it” and provided a person has enough provisions to leave for his family in his absence . . .

Many countries have imposed restrictions on the number of outgoing pilgrims because of foreign-exchange difficulties . . . **All Muslim countries** send **official delegations** on the occasion, which is being increasingly used for **religio - political congresses**. At other times in the year, it is considered meritorious to perform the lesser pilgrimage (*'umrah*), which is not, however, a substitute for the *hajj* pilgrimage.

The most sacred place for Muslims is the Ka'bah sanctuary at Mecca, the object of the annual pilgrimage. It is much more than a mosque; it is believed to be the place where the heavenly bliss and power touches the earth directly. According to Muslim tradition, the Ka'bah was built by Abraham. The Prophet's mosque in Medina is the next in sanctity. Jerusalem follows in third place in sanctity as the first *qiblah* . . . and as the place from where Muhammad, according to tradition, made his ascent (*mi'raj*) to heaven . (\*6) ] ((\*1 - \*6) Copyright © 1994-2002 Encyclopædia Britannica, Inc; 2002 Deluxe Edition CD-Rom v2002.01.0002.0)

In the above quotes from the Encyclopedia Britannica I have highlighted a very few portions. However, notice that throughout the centuries - Islam has mostly advanced solely thru warfare and **conquest** of various peoples. The very word *Islam* means **surrender**. Surrender to the *will* of God. However, Islam

believes and teaches - that surrender to God is solely accomplished by converting to Islam. Thru **warfare**, subjugation, **conquest**, and the far reaching influence of Muslim traders - Islam became a world wide religion. With the fact of Muslims being solidified together by their faith - resulting in their sense of belonging to a single community; this [faith of Islam then helped various Muslim peoples in their struggle to gain political freedom in the mid - 20<sup>th</sup> century and the unity of Islam contributed to later political solidarity. (2002 CD Britannica) ] Today, Islam is a huge, worldwide, major religious community of various ethnic backgrounds - using the **annual** pilgrimage for religious and **political purposes** combined.

In September 2010; what of the controversy of building a Mosque very near where the World Trade Center Towers (*New York City*) were destroyed by Muslim terrorists? And over three thousand people died. The proposal to build this Mosque - is on a piece of land where the bodies of some people fell, and landing gear from at least one plane landed. Why do I bring this up??

The name of this Mosque proposal is called the **Cordoba Initiative**, or Cordoba Project. But, the word **Cordoba** - has meaning and significance in the Islamic tradition and culture. The proposers of this construction - state that it is to **build bridges** between communities. Of course, the *will of Allah* is for all to convert to Islam, or for the 'people of the book' to subjugate themselves to Islam in taxes; and for everyone else to die. **Surrender** to the will of God or Allah.

What is the historical meaning, and significance of the word **Cordoba**, with regards to Islam?

[*(English Cordova)* Córdoba was probably Carthaginian in origin and was occupied by the Romans in 152 BC. The city flourished under their rule, though 20,000 of its inhabitants were massacred in 45 BC by Julius Caesar for having supported the sons of Pompey . . . In 711 Córdoba was **captured** and largely **destroyed** by the **Muslims**. Its recovery was impeded by tribal rivalries until 'Abd ar-Rahman I, a member of the Umayyad family, accepted the **leadership of the Spanish Muslims** and made Córdoba his capital in 756. 'Abd ar-Rahman I founded the **Great Mosque of Córdoba**, which was enlarged by his successors and completed about 976 by Abu 'Amir al-Mansur. Though troubled by occasional revolt, Córdoba grew rapidly under Umayyad rule; and after 'Abd ar-Rahman III proclaimed himself caliph of the West in 929, it became the largest and probably the most cultured city in Europe. Under Umayyad rule, **Córdoba** was enlarged and **filled with palaces and mosques** . . . When the caliphate was dismembered by civil war early in the 11th century, **Córdoba** became the **centre** of a **contest for power** among the petty **Muslim kingdoms** of Spain . . .

The original structure was built by the Umayyad ruler 'Abd ar-Rahman I in 784–786 with extensions in the 9th and 10th centuries that doubled its size, ultimately making it **one of the largest sacred buildings in the Islamic world.**] (Copyright © 1994-2002 Encyclopædia Britannica, Inc; 2002 Deluxe Edition CD-Rom v2002.01.0002.0)

With regards to Islam conquering the world, and the rider holding a Bow - being given a crown - and going out on a white horse as a conqueror, bent on conquest . . . What are some of the statements made by Islamic Presidents, Leaders, and clerics worldwide in relatively recent history??

\*\*\*\*\*

**[Fard, Wallace D.**

also called **Walli Farrad, Farrad Mohammed, F. Mohammed Ali, or Wallace Fard Muhammad**  
(b. c. 1877, Mecca—d. 1934?), Mecca-born founder of the Nation of Islam (sometimes called Black Muslim) movement in the United States.



Fard immigrated to the United States sometime before 1930. In that year, he established in Detroit the Temple of Islam as well as the University of Islam, which was the temple's school, and the Fruit of Islam, a corps of male guards.

Fard preached that blacks (who were not to be called Negroes) must prepare for an **inevitable race war** and that **Christianity** was the *religion of slave-owners* . . . ] (Copyright © 1994-2002 Encyclopædia Britannica, Inc; 2002 Deluxe Edition CD-Rom v2002.01.0002.0)

\*\*\*\*\*

Mahmoud Ahmadinejad (Iranian President); 7/04

Islam would **conquer** all the mountain tops of the world.

\*\*\*\*\*

Sheik Ali Al-Faqir (Former Jordainain Minister of Religious Endowment); 5/2/08

Islam would **conquer** Rome, and that Islam would **rule the world**. And that what has begun will be completed. It will **not stop**. And that **America** has proclaimed, like Pharaoh, "I am your supreme God," but it **will come to its end**. Their end is near. We say now that **America** and the **EU** will **come to an end**, and only the rising force of **Islam** will prevail.

\*\*\*\*\*

Egyptian cleric Salem Abu Al-Futuh; Al-Nas TV; 8/18/10

The nation of Islam will return – despite our current crisis and despite the arrogance of the West. The **West is bound to be destroyed**. Just like Allah destroyed the Byzantine and Persian empires, he will **destroy the West** at the **hands** of the **Muslims**. This is an **unequivocal promise**. These countries will convert to Islam. Islam will reach these countries.

. . . Let us examine the divine sequence: First, the **Caliphate will return**. Then, the **Muslims** will live in tremendous **prosperity**. The economy of the Muslims will be the strongest of all. You are probably thinking that I'm not well today if I say such things. By God, there's nothing wrong with me. I am speaking **words of truth**.

. . . Great **conquests** will ensue. We will **conquer Italy**... By Allah, we **will conquer Italy**. By **Allah**, we will **conquer Italy** and move into [the rest] of Europe. **Islam will enter that entire region**. Even **America**, you ask? Yes, even America. North or South America? Both North and South America. We will **enter all these countries**, and people there will be **joining Islam in droves**.

\*\*\*\*\*

Hamas MP and cleric Yunis Al-Astal; Al-Aqsa TV; 4/11/08

Allah has chosen you for Himself and for His religion, so that you will serve as the engine pulling this nation to the phase of succession, security, and **consolidation of power**, and even to **conquests** thorough da'wa and **military conquests** of the **capitals** of the **entire world**. Very soon, Allah willing, **Rome will be conquered**, just like Constantinople was, as was prophesied by our Prophet Muhammad. Today, Rome is

*the capital of the Catholics, or the Crusader capital, which has **declared its hostility to Islam**, and has planted the brothers of apes and pigs in Palestine in order to prevent the reawakening of Islam – this capital of theirs will be an advanced post **for the Islamic conquests**, which will spread through **Europe** in its **entirety**, and then will **turn to the two Americas**, and even Eastern Europe.*

\*\*\*\*\*

Similar statements and comments of the above are routinely made by numerous other Muslim clerics, as widely documented by MEMRI ([www.memritv.org](http://www.memritv.org)) and Palestinian Media Watch ([www.palwatch.org](http://www.palwatch.org))

To sum up the first seal - it has obviously been opened. It might have initially been opened when Muhammad founded Islam in Medina. This is a religion of 'peace' propagated almost entirely by conquest. When Jesus gave the prophecy of Revelation - He stated that it was because the **time was near**.

*Blessed is the one who reads the words of this prophecy, and blessed are those who hear it and take to heart what is written in it, **because the time is near**.* (Rev 1:3)

*The revelation of Jesus Christ, which God gave him to show his servants **what must soon take place** . . .* (Rev 1:1)

Islam has 'obviously' been conquering for quite some time. So it is possible the seal was opened quite some time ago; and not just in the recent past. It is also possible that although Islam is destined to take over the world; this massive religious deception was given the final authority to totally conquer just in the very recent past.

I am not stating that the anti-Christ will be a Muslim; or that Islam will be the ultimate world religion. Christians who are deceived will probably recognize the anti-Christ as Jesus returned. Muslims will probably state the anti-Christ is Muhammad returned; or the *Caliphate*. The anti-Christ will be extremely powerful - and WILL be **worshiped** by the entire **world**. Don't quite know precisely what his religious beliefs will be - except that they will be against God - while causing everyone to believe they are worshiping God.

*. . . The **whole world was astonished** and followed the beast.* (Rev 13:3)

*Men **worshiped** the dragon . . . and they also **worshiped** the beast . . .* (Rev 13:4)

*All inhabitants of the **earth will worship the beast** . . .* (Rev 13:8)

*He was given power to give breath to the image of the first beast, so that it could speak and cause all who **refused to worship** the image to be killed.* (Rev 13:15)

2<sup>nd</sup> seal.

*When the Lamb opened the second seal, I heard the second living creature say, "**Come!**" Then another horse came out, a **fiery red** one. Its rider was given **power to take peace** from the earth and to make men **slay** each other. To him was given a **large** sword.* (Rev 6:3 - 4)

This second seal has stated consequences. First, the heavenly command "**Come!**". The color of the horse is Red - which carries the meaning of war. The planet *Mars* is classically considered to represent the God

of **War**; and its color from earth is Red. And red carries the meaning of bloodshed. Blood freely flowing.

When Christ was born - **God** pronounced **PEACE** to the earth. He literally gave us **PEACE**. Jesus did not come to slay men, but to give life!.

*“Glory to God in the highest, and **on earth peace** to men on whom his favor rests.”* (Luke 2:14)

*When the disciples James and John saw this, they asked, “Lord, do you want us to **call fire down** from heaven to **destroy** them?” But Jesus turned and rebuked them.* (Luke 9:54 - 55)

But in the second seal - God is calling out Bloodshed on the earth! He has removed the peace he bestowed; and instead is commanding War and the shedding of much Blood. The rider of the **fiery red πυρρός** (*the color of fire*) horse is given power to **take peace from the earth . . .** and to **make men slay each other!** He was given a large **μεγάλη** (*great; spatially: large; of quantity or degree: loud, intense, violent; of time: long (time); of position: great, important*) sword. This is an intense and violent sword - of great position and importance. It removes PEACE from the earth. Only if you're a Christian, and daily allowing yourself to be washed by the Holy Spirit; and understand and rejoice in this prophecy which is Revelation - will you have any possibility of retaining the Peace of God! MANY will fall away! KNOW the times in which we live. LEARN to HEAR the Spirit of GOD; and wash yourself in Revelation - which **JESUS** gave - so that you could know what was going to happen - and still have PEACE!

*“I, **Jesus**, have sent my angel to **give you this testimony . . .**”* (Rev 22:16)

You *have* noticed the *numerous* instances of various people killing one another; of rumors of various wars; and of individuals being **beheaded** - haven't you??

*. . . And I saw the souls of those who had been **beheaded** because of their **testimony for Jesus** and because of the word of God. They had **not worshiped the beast** or his image and had not received his mark . . .*  
(Rev 20:4)

*He who has an ear, **let him hear**. If anyone is to go into captivity, into captivity he will go. If anyone is to be **killed with the sword**, with the **sword he will be killed**. This calls for **patient endurance** and **faithfulness** on the part of the saints.* (Rev 13:9 - 10)

3<sup>rd</sup> Seal.

*When the Lamb opened the third seal, I heard the third living creature say, “**Come!**” I looked, and there before me was a **black** horse! Its rider was holding a pair of **scales** in his hand. Then I heard what sounded like a voice among the four living creatures, saying, “A **quart of wheat** for a day's wages, and three quarts of barley for a day's wages, and do not damage the **oil and the wine!**”* (Rev 6:5 - 6)

We have the important command: “**Come!**” And then a **Black** horse. The color **Black** has long been associated with **death**. In many cultures; **mourning** for the death of a loved one - is indicated by the wearing of **Black** clothes. We have the phrase: “Black Death” for both bubonic and pneumonic plagues.

*“Son of man, with one blow I am about to take away from you the delight of your eyes. **Yet do not lament** or weep or shed any tears. Groan quietly; **do not mourn for the dead**. Keep your turban fastened and your sandals on your feet; do not cover the lower part of your face or eat the customary food of*

*mourners.*” (Ezekiel 24:16 - 17)

. . . *The sun turned black like sackcloth made of goat hair . . .* (Rev 6:12)

*Then Jacob tore his clothes, put on sackcloth and mourned for his son many days.* (Genesis 37:34)

*In every province to which the edict and order of the king came, there was great mourning among the Jews, with fasting, weeping and wailing. Many lay in sackcloth and ashes.* (Esther 4:3)

*Their princes were brighter than snow and whiter than milk, their bodies more ruddy than rubies, their appearance like sapphires. But now they are blacker than soot; they are not recognized in the streets. Their skin has shriveled on their bones; it has become as dry as a stick. Those killed by the sword are better off than those who die of famine; racked with hunger, they waste away for lack of food from the field.* (Lamentations 4:7 - 9)

*The churning inside me never stops; days of suffering confront me. I go about blackened, but not by the sun; I stand up in the assembly and cry for help. I have become a brother of jackals, a companion of owls. My skin grows black and peels; my body burns with fever.* (Job 30:27 - 30)

*O my people, put on sackcloth and roll in ashes; mourn with bitter wailing as for an only son, for suddenly the destroyer will come upon us.* (Jeremiah 6:26)

The rider was holding a pair of scales. These are used to measure out very small portions of food commodities. And the available food - is sold at exorbitant prices. Which indicates widespread scarcity of even basic food supplies.

[Barley was one of the most important grains raised in Pal. {*Palestine; or traditionally Philistia or Philistine homeland \**}. It was grown chiefly for horses and asses, but was also eaten by the poor.

As barley was largely the food of the poor, it was looked down on, and is even scorned today . . . Arabs today refer to Jews as “cakes of barley.” This is a scornful term. The true followers of Mohammed are “wheat” and the Jews are “barley.” The Midianites probably called the Israelites “cakes of barley” (Judg 7:13), and that was why in a dream a soldier saw “a cake of barley bread tumbled into the camp of Midian.”

(Barley Harvest & Barley; both from Zondervan Pictorial Encyclopedia of the Bible; Pradis CD-ROM v4.0.1 {*\* author's note*})]

Consequently - the description is of a small amount of wheat - requiring a full day's wages; and food deemed worthy only of livestock or the poor - you may obtain just a bit more - for a day's wages . . .

The command is included not to harm or damage the Oil and the Wine. This could be a literal preservation of crops such as olives and grapes. From which come olive oil and wine. I don't believe this to be so . . . The Holy Spirit is often referred to as 'oil'; and 'new wine'. In the midst of increasing calamity - this is a command to not 'damage' a group of very special Christians. They are special - only because of their tremendous intimacy of and LOVE towards Jesus and others.

. . . *the LORD has sought out a man after his own heart and appointed him leader of his people, because you have not kept the LORD'S command.*” (1 Samuel 13:14)

*After removing Saul, he made David their king. He testified concerning him: 'I have found David son of*

Jesse a man after *my own heart*; he will *do everything* I want him to do.’ (Acts 13:22)

. . . Then the LORD said, “Rise and *anoint* him; he is the one.” So Samuel took the *horn of oil* and him in the presence of his brothers, and from that day on the *Spirit of the LORD* came upon David in *power* . . .  
(1 Samuel 6:12 - 13)

A new *command* I give you: *Love* one another. As *I* have *loved* you, so *you* must *Love* one another.  
(John 13:34)

The goal of this *command is love*, which comes from a *pure heart* and a good conscience and a *sincere faith*. (1 Timothy 1:5)

And he has given us this *command*: *Whoever* loves *God* must also *love his brother*. (1 John 4:21)

Jesus answered, “How can the *guests of the bridegroom* fast while he is with them? They cannot, so long as they have him with them. But the time will come when the bridegroom will be taken from them, and on that day they will fast. “No one sews a patch of unshrunk cloth on an old garment. If he does, the *new piece will pull away from the old*, making the tear worse. And no one *pours new wine* into old wineskins. If he does, the wine will burst the skins, and both the wine and the wineskins will be ruined. No, he pours *new wine into new wineskins*.” (Mark 2:19 - 22)

Therefore, if anyone is in Christ, he is a *new creation*; the *old* has gone, the *new* has come! (2 Corinthians 5:17)

Do not get *drunk on wine*, which leads to debauchery. Instead, be *filled with the Spirit*. (Ephesians 5:18)

These men are *not drunk*, as you suppose. It’s only nine in the morning! No, this is what was spoken by the prophet Joel: “ ‘In the last days, God says, I will *pour out my Spirit* on all people. Your sons and daughters *will prophesy* . . . (Acts 2:15 - 17)

“At that time the *kingdom of heaven* will be like ten *virgins* who took their *lamps* and went out to meet the bridegroom. Five of them were foolish and five were wise. The foolish ones took their lamps but did *not take any oil* with them. The wise, however, *took oil in jars* along with their lamps. The bridegroom was a long time in coming, and they all became drowsy and fell asleep. “At midnight the cry rang out: ‘Here’s the bridegroom! Come out to meet him!’ “Then all the virgins woke up and trimmed their lamps. The foolish ones said to the wise, ‘*Give us some of your oil*; our lamps are going out.’ “ ‘No,’ they replied, ‘there may not be enough for both us and you. Instead, go to those who sell oil and buy some for yourselves.’ “But while they were on their way to buy the oil, the bridegroom arrived. The *virgins* who were *ready* went in with him to the wedding banquet . . . (Matthew 25:1 - 10)

*Oil and wine* have immense spiritual significance for a Christian, and in God’s economy. Here, the 3<sup>rd</sup> seal declares that the World’s food crop is going to be ultimately devastated; but the Bride of Christ is going to be preserved . . . this *Oil and Wine* reference is specifically discussing the *Bride of Christ*. From the 5<sup>th</sup> seal, and numerous other Revelation scriptures - (such as chapter 12); it is obvious that a substantial number of Christians are going to be experiencing the tribulation . . .

Then the dragon was enraged at the woman and went off to make war against the rest of her offspring - those who obey God’s commandments and hold to the testimony of Jesus. (Rev 12:17)

4<sup>th</sup> Seal.



When the Lamb opened the fourth seal, I heard the voice of the fourth living creature say, “**Come!**” I looked, and there before me was a **pale horse!** Its rider was named **Death**, and **Hades** was following close behind him. They were given power over a fourth of the earth to **kill** by **sword, famine and plague**, and by the **wild beasts** of the earth. (Rev 6:7 - 8)

We have the all important command: **COME!**

The color of this horse is **pale** or **green**. **χλωρός** (light green; pale; (n.) green plant) It is the same word used when stating to sit on **green grass** in Mark 6:39 or Rev 8:7 (**green** grass) or Rev 9:4 (any **plant** or tree.)

## **[Jibril**

*also spelled Jabra'il*

in *Islam*, the archangel who acts as intermediary between God and man and as bearer of revelation to the prophets, most notably, to Muhammad . . .

Muhammad generally only heard the voice of his inspiration, but, according to 'A'ishah, his wife, he saw Jibril twice “in the shape that he was created” and on other occasions as a man resembling Dihyah ibn Khalifah al-Kalbi, an extraordinarily handsome disciple of Muhammad. Others have described the archangel as having 600 wings, each pair so enormous that they crowd the space between East and West. Jibril has also been depicted as sitting on a chair suspended between heaven and earth. The popular image of Jibril is of an ordinary, turbaned man, dressed in two **green** garments, astride a **horse** . . . ] (Copyright © 1994-2002 Encyclopædia Britannica, Inc; 2002 Deluxe Edition CD-Rom v2002.01.0002.0)

**[The color of Islam is Green.** It represents the Freshness of a Healthy Spiritual Lifestyle . . . The color green as the color of Islam was first used by the prophet himself. The color of the Islamic flag was green. To Muslims, **green represents the freshness of Islam** and how it is meant to bring the mind of the Muslim from ignorance into light . . .

At the **advent of Islam**, represented by the **color green**, the freshness of religion returned for the worship of God. The freshness and true purpose of the Kaaba that was established by Abraham was resurrected. The Muslims were charged with its maintenance . . .

The color green is seen everywhere in the physical world as well as the spiritual. In the far East it is representational of the life-force that emanates from the heart and the seat of humanities love and emotional well being . . . The Teacher of Moses was known as Al-Khidr (literally. “the **green one**”) . . .

The **color green** is a universal symbol of **love, peace, harmony**, well-being, freshness, and honesty; elements that will improve the world as humanity strives to “go green.”] (4/29/09; by Khalil Green; from the website ([www.suite101.com/content/the-color-of-islam-is-green-a113707](http://www.suite101.com/content/the-color-of-islam-is-green-a113707)))

And of course, **green** represents plants, crops, and a new season. With each new spring - plants turn green, and life becomes abundant. Here though - God is calling forth immense plagues and destruction. And so - with the color **Green** normally associated with Life; here we have the exact *opposite* (anti-Christ.) The color **green** or **pale** - is being used to signify **Death**.

This is an immense acceleration of the previous three seals. The *first* seal gave great authority and power to a false religion - to *conquer*. The conquering includes death to those who refuse to *surrender* to the

will of Allah.

The second seal gives the rider a large **μεγάλη** sword. The rider removes peace; and makes men **SLAY** one another.

(*great; spatially: large; of quantity or degree: loud, intense, violent; of time: long (time); of position: great, important*)

**σφάξουσιν** (to kill, slay, murder)

The third seal declares an insufficient food supply - along with extreme prices. Numerous people will die from lack of food.

But now - the fourth seal accelerates the death. Islamic warriors routinely kill people by the sword. Cutting their heads off. Lack of food results in famine, and disease - since the body cannot ward off sickness. And when you are very hungry, and poor - correct hygiene is not generally uppermost on your mind. And when a severe lack of food exists - animals (wild beasts) do not have much to eat either. And when the problem becomes severe enough - wild animals search for *any* possible available food.

The fourth seal brings massive, *Massive* DEATH. That is what it does. Period. It accelerates the previous three seals.

Currently, the world global population is slightly over Seven Billion. One fourth of that would be: 1 Billion, 750 Million people dead from this one seal alone.

*Distressed and hungry, they will roam through the land; when they are **famished**, they will become **enraged** and, looking upward, **will curse** their king and their **God**. Then they will look toward the earth and see only distress and darkness and fearful gloom, and they will be thrust into utter darkness.*

(Isaiah 8:21 - 22)

*For then there will be **great distress**, **unequaled** from the **beginning of the world** until now - and **never** to be equaled again. If those days had not been cut short, **no one would survive**, but for the **sake of the elect** those days will be shortened.* (Matthew 24:21 - 22)

*The rest of mankind that were not **killed by these plagues** still did not repent of the work of their hands . . .*  
(Rev 9:20)

*They were seared by the intense heat and they **curse** the name of **God**, who had **control** over these **plagues**, but they **refused to repent** and glorify him.* (Rev 16:9)

5<sup>th</sup> Seal.

*When he opened the fifth seal, I saw under the altar the souls of those who had been **slain** because of the **word of God** and the **testimony** they had maintained. They called out in a loud voice, "How long, Sovereign Lord, holy and true, until you **judge** the **inhabitants of the earth** and **avenge our blood**?" Then each of them was given a **white robe**, and they were told to **wait** a little longer, until the number of their **fellow servants and brothers** who were to be **killed** as they had been was **completed**.* (Rev 6:9 - 11)

And now Jesus or the *Lamb* - opens the fifth seal. These three verses are mostly self-explanatory. Individuals who are being persecuted and killed because of their Christian faith and the testimony they maintained - are crying out to God for judgement. Judgement upon those who killed them. Judgment upon the inhabitants of the earth. The inhabitants of the earth absolutely HATE Christians at this time.

They rejoice in their deaths, and they rejoice in killing them.

*For three and a half days men from every people, tribe, language and nation will gaze on their bodies and refuse them burial. The inhabitants of the earth will gloat over them and will celebrate by sending each other gifts . . . (Rev 11:9 - 10)*

*“Brother will betray brother to death, and a father his child. Children will rebel against their parents and have them put to death. All men will hate you because of me, but he who stands firm to the end will be saved. (Mark 13:12 - 13)*

*After this I looked and there before me was a great multitude that no one could count, from every nation, tribe, people and language, standing before the throne and in front of the Lamb. They were wearing white robes . . . . “These are they who have come out of the great tribulation; they have washed their robes and made them white in the blood of the Lamb. (Rev 7:9, 14)*

Now, the *word of God* and the *testimony* they had maintained - is NOT quoting the Bible! Satan and the Beast will be quoting the Bible and scriptures. The *word of God* - is HEARING what the Holy Spirit is speaking to you; and speaking it out. It is speaking the very words of God. It is not memorizing scripture, and stating: “the Bible says this . . .” People will not care what the Bible says. They will easily quote the Bible themselves . . .

*If anyone speaks, he should do it as one speaking the very words of God. If anyone serves, he should do it with the strength God provides, so that in all things God may be praised through Jesus Christ . . . (1 Peter 4:11)*

*Whenever you are arrested and brought to trial, do not worry beforehand about what to say. Just say whatever is given you at the time, for it is not you speaking, but the Holy Spirit. (Mark 13:11)*

*He who has an ear, let him Hear what the Spirit says to the churches. (Rev 3:13)*

*He who has an ear, let him hear. If anyone is to go into captivity, into captivity he will go. If anyone is to be killed with the sword, with the sword he will be killed. This calls for patient endurance and faithfulness on the part of the saints. (Rev 13:9 - 10)*

Now, in these three verses discussing the saints who die for *the word of God and the testimony they had maintained* . . . what is not self-explanatory - is the context and *timing* of the fifth seal.

The previous four seals all carried a most *important* command. The command was: **COME!** This seal, and the sixth seal to follow; do not carry this command. In this prophecy which is Revelation - the consequences of the other four seals - start to HAPPEN when Jesus opens them. However, the fifth and the sixth seal - are *PROPHETIC* seals within the *Prophecy* which is Revelation. These last two seals briefly give a very broad overview of what is going to happen to the people who refuse to worship the beast; and those who do . . .

6<sup>th</sup> Seal.

*I watched as he opened the sixth seal. There was a great earthquake. The sun turned black like sackcloth made of goat hair, the whole moon turned blood red, and the stars in the sky fell to earth, as late figs drop from a fig tree when shaken by a strong wind. The sky receded like a scroll, rolling up, and every*

*mountain and island was removed from its place. Then the kings of the earth, the princes, the generals, the rich, the mighty, and every slave and every free man hid in caves and among the rocks of the mountains. They called to the mountains and the rocks, "Fall on us and hide us from the face of him who sits on the throne and from the wrath of the Lamb! For the great day of their wrath has come, and who can stand?"* (Rev 6:12 - 17)

The sixth seal describes MAJOR environmental changes. All mountains and islands are destroyed. *Huge* earthquake(s). The sun turning BLACK, stars (not angels) disappearing; the Heavens or Universe being violently shaken (receding like a scroll) . . . etc.

All peoples who are left on the planet (YES - all servants of and believers in CHRIST are finally, totally WITH HIM - at this point) are totally trembling in TERROR and FEAR - and are now answering their own question which they had *previously* (R13:4) asked . . . "*Who can make war against him??*" Answer: **JESUS**. Not even the Anti-Christ can stand *against JESUS*, or the wrath of the LAMB! Although amazingly enough - Satan manages to continue to deceive, 'rallies the troops'; and the armies of the world still go off to make war against Jesus.

But here - the world has temporarily forgotten that they have this 'HUGE', POWERFUL' leader behind them; supporting them - and they are absolutely TERRIFIED at the coming wrath of the True God.

. . . *the rich, the mighty, and every slave and every free man hid in caves and among the rocks . . .* (Rev 6:15)

*Men worshiped the dragon because he had given authority to the beast, and they also worshiped the beast and asked, "Who is like the beast? Who can make war against him?"* (Rev 13:4)

. . . "*If anyone worships the beast and his image and receives his mark on the forehead or on the hand, he, too, will drink of the wine of God's fury . . .*" (Rev 14:9 - 10)

*The fourth angel poured out his bowl on the sun, and the sun was given power to scorch people with fire. They were seared by the intense heat . . .* (Rev 16:8 - 9)

[Note: in the above verse - you can easily see *why* all the world wide hysteria in regards to *Global Warming*; or *Climate Change*. Satan who currently RULES this earth, is very aware of some of the plagues, and stuff which God is going to do . . . And since Satan only wishes to steal, kill, and destroy; he is setting mankind up to accept scientific explanations for some of what is going to happen . . .]

. . . *all the peoples of the earth will mourn because of him . . .* (Rev 1:7)

*Then there came flashes of lightning, rumblings, peals of thunder and a severe earthquake. No earthquake like it has ever occurred since man has been on earth, so tremendous was the quake. The great city split into three parts, and the cities of the nations collapsed. God remembered Babylon the Great and gave her the cup filled with the wine of the fury of his wrath. Every island fled away and the mountains could not be found.* (Rev 16:18 - 20)

*Men will flee to caves in the rocks and to holes in the ground from dread of the LORD and the splendor of his majesty, when he rises to shake the earth.* (Isaiah 2:19)

Then " 'they will say to the mountains, "Fall on us!" and to the hills, "Cover us!" ' " (Luke 23:30)

*The angel swung his sickle on the earth, gathered its grapes and threw them into the great **winepress** of **God's wrath**. They were trampled in the winepress outside the city, and **blood flowed** out of the press . . .*  
(Rev 14:19 - 20)

(Chapter 7)

*After this I saw **four angels** standing at the four corners of the earth, **holding back** the **four winds** of the earth to prevent **any wind** from blowing on the **land** or on the **sea** or on **any tree**. Then I saw another angel coming up from the east, having the seal of the living God. He called out in a loud voice to the four angels who had been **given power to harm** the land and the sea: "**Do not harm** the land or the sea or the trees **until** we put a **seal** on the **foreheads** of the **servants of our God**." (Rev 7:1 - 3)*

Here, we have a brief prophetic description of four angels; and what they are **going** to do . . . The first verse stating they were **holding back the four winds** - is symbolic *and* prophetic. It indicates the great harm and destruction they are going to accomplish. And they are commanded that it is not quite time to do this; and to wait for a group of individuals to be identified. If all wind on the Earth stopped - it would be very, very bad! No rain; no movement of atmosphere; no refreshment of a sea breeze; or movement of 'fresh air'. All types of trees and plants would cease to live; and the atmosphere would become even worse. Tremendous harm and destruction would result . . .

And, these are not '**good**' angels; patiently waiting on God to accomplish God's will. No, these are *fallen angels* - who only wish to destroy mankind. In chapter Nine; we see a description of their release, and the subsequent results . . .

*It said to the sixth angel who had the trumpet, "**Release** the four angels who are bound **δεδεμένους** (to tie, bind, imprison) at the great river Euphrates." And the **four angels** who had been kept ready for this very hour and day and month and year were **released** to **kill** a third of mankind. (Rev 9:14 - 15)*

So - we have these 'four' angels who only wish to kill and destroy. But they are told it is not quite time; and they must wait to harm man and the earth - until a **seal** is put on the *foreheads of the servants of our God*.

When a person becomes saved - they receive a seal from God. The Holy Spirit **indwells** them; and **seals** and **proves** that they have been born again - and are a new creation in Christ.

*And he received the sign of circumcision, a **seal** of the **righteousness** that he had by faith while he was still **uncircumcised**. (Romans 4:11)*

*Even though I may not be an **apostle to others**, surely I am to you! For you are the **seal** of my **apostleship** in the Lord. (1 Corinthians 9:2)*

*Now it is God who makes both us and you stand firm in Christ. He **anointed** us, **set his seal of ownership** on us, and put his **Spirit** in our hearts as a **deposit**, **guaranteeing** what is to come. (2 Corinthians 1:21 - 22)*

*. . . Having **believed**, you were **marked** in him with a **seal**, the promised **Holy Spirit**, who is a **deposit guaranteeing** . . . (Ephesians 1:13 - 14)*



And do not grieve the *Holy Spirit* of God, with whom you were *sealed* for the day of redemption. (Ephesians 4:30)

However - this group of people (the twelve tribes of Israel) are *already* saved. They are believers. The command is to put a *seal* on the *servants* of our God. When a person is born again - he/she is automatically sealed to God. And this group of individuals are already saved and believe in Christ. Therefore - the seal which is being discussed - is **not** the seal of *salvation*. It is a seal for a *different* purpose.

Some might believe these are twelve tribes of Jews - who get saved just in the 'nick of time'. Or are a small group of believers who become saved during the tribulation period - because of the 'preaching' of the *two witnesses*. (R11) **Not** so! We shall see shortly just who these are - but for now accept that they are saved, and are *already* believers - who are, and *have been* - sealed with the Holy Spirit!

In chapter seven, the seal being discussed - is not the redemption seal of salvation.

*Even though I may not be an apostle to others, surely I am to you! For you are the seal of my apostleship in the Lord.* (1 Corinthians 9:2)

The above is an example of a *seal* of apostleship - but **not** of salvation. It is a seal indicating *Authority*.

Was Jesus *sealed*?? Did he need a *seal* from God - *guaranteeing* his *salvation*? The salvation He himself provides?? Speaking of Himself - Jesus stated:

*Do not work for food that spoils, but for food that endures to eternal life, which the Son of Man will give you. On him God the Father has placed his seal of approval.*” (John 6:27)

We see that the word *seal* - may be used in the context of *servants of God* - to indicate something *other* than salvation. It is the indicator of Paul's authority as an *apostle*; and the seal is actually a group of believers whom he has poured his life into . . . And Jesus spoke of receiving a *seal of approval* from the Father.

So with regards to believers - the word seal - is not always used to indicate a person being saved - or as a guarantee. In the NT; there are three Greek words total - which may be translated in a form to indicate some type of *seal*.

**κατεσφραγισμένον** ((pass.) to be sealed up) [Rev 5:1] {G2958}

**σφραγίδα** (seal) [Ro 4:11; 1Co 9:2; 2Ti 2:19; Rev 5:1,2,5,9 /6:1,3,5,7,9,12 /7:2 /8:1 /9:4] {G5382}

**σφραγίσαντες** (to seal, to put a mark on an object to show possession, authority, identity, or security) [Mt 27:66; Jn 3:33 /6:27; Ro 15:28; 2Co 1:22; Eph 1:13 /4:30; Rev 7:3,4,5 /10:4 /20:3 /22:10] {G5381}

These are translated as:

G2958: *sealed*

G5382: *seal, seals, sealed with*

G5381: *sealed, seal up, set seal of ownership on, putting a seal on, put a seal, on placed seal of approval, marked with a seal, made sure that, certified*, [and not translated into the English from the Greek - 2 times]

And demons recognize who is **owned** by and **possessed by God**. They recognize the Holy Spirit dwelling within a person. They do not need a special ‘marker’ on the forehead - to know whom **God** has **purchased** by His **blood**!

“What do you want with us, **Son of God?**” they shouted. “Have you come here to torture us before the appointed time?” (Matthew 8:29)

Once when we were going to the place of prayer, we were met by a slave girl who had a spirit by which she predicted the future. She earned a great deal of money for her owners by fortune - telling. This girl **followed Paul** and the **rest of us**, shouting, “These **men** are **servants of the Most High God**, who are telling you the way to be saved.” (Acts 16:16 - 17)

Some Jews who went around driving out evil spirits **tried to invoke** the name of the **Lord Jesus** over those who were demon - possessed. They would say, “In the name of **Jesus, whom Paul preaches**, I command you to come out.” Seven sons of Sceva, a Jewish chief priest, were doing this. One day the **evil spirit answered** them, “**Jesus I know, and I know about Paul, but who are you?**” Then the man who had the evil spirit jumped on them and overpowered them all . . . (Acts 19:13 - 16)

Moreover, **demons** came out of many people, shouting, “**You are the Son of God!**” But he rebuked them and would **not allow them to speak**, because they **knew** he was the Christ. (Luke 4:41)

In (R9:4); **harm** is **allowed** on those who do **not** have the seal of God on their foreheads. The emphasis is on those who are not saved. The emphasis is on unbelievers.

They were told not to harm the grass of the earth or any plant or tree, but only **those people who did not have the **seal of God** on their foreheads.** (Rev 9:4)

In the above verse - the **seal of God** does directly relate to salvation, and to those who are standing firm in Christ. And harm is being directed at unbelievers . . .

Chapter seven opens up with the scriptures and God desiring to create a juxtaposition. God wishes to draw your attention and notice - to two **different** groups of believers. We count a group of believers or **Jews**; and then we immediately go to a group who cannot be counted . . . We call out one; and then the other . . . The **twelve tribes** of Israel, and **a great multitude that no one could count!** (R7:9) A comparison of believers. Why?? Why does God give us this **juxtaposition?** What is the **purpose** of the comparison?

FIRST OFF: **All** believers are **sealed!** But not necessarily sealed in the same way. Christ was obviously a man - who walked the earth. But he had a tremendous relationship with God. And Christ was God. Enoch sinned, but yet he had a tremendous relationship with God; so God took him. (Ge 5:24; Heb 11:5) Jesus spoke of positions of leadership and authority in Heaven. And Paul did as well. Salvation is not from works - it is totally from **Faith**; yet God honors our intimacy, trust, and obedience to Him.

I tell you the **truth**: Among those born of women there has not risen **anyone greater** than John the Baptist; yet he who is **least** in the **kingdom of heaven** is **greater** than he. (Matthew 11:11)

For no one can lay any foundation other than the one already laid, which is Jesus Christ. If any man **builds** on this foundation using **gold, silver, costly stones, wood, hay or straw**, his **work** will be shown for what it is, because the **Day will bring it to light**. It will be **revealed with fire**, and the fire will **test** the quality of each man's work. If what he has built **survives**, he will receive his **reward**. If it is **burned up**, he will **suffer loss**; he **himself** will be **saved**, but **only** as one **escaping through the flames**. (1Corinthians 3:11 - 15)

In the same way, **faith** by itself, if it is **not** accompanied by **action, is dead**. But someone will say, "You have faith; I have deeds." Show me your **faith without deeds**, and I will show you **my faith by what I do**. You believe that there is one God. Good! Even the demons believe that - and shudder. You foolish man, do you want evidence that **faith without deeds is useless**? (James 2:17 - 20)

**Wake up!** Strengthen what remains and is about to die, for I have not found **your deeds complete** in the sight of my God. (Rev 3:2)

GOD **rewards** us for what we DO for him, and in Him. God rewards people per **His** standard. Not mine! Not yours!

**Blessed** are you when people insult you, persecute you and falsely say all kinds of evil against you because of me. **Rejoice** and be glad, because great is your **reward in heaven**, for in the same way they persecuted the prophets who were before you. (Matthew 5:11 - 12)

"**Rejoice** in that day and **leap for joy**, because **great** is your **reward** in heaven . . . (Luke 6:23)

Serve wholeheartedly, as if you were serving the Lord, not men, because you know that the **Lord** will **reward everyone for whatever good he does** . . . (Ephesians 6:7 - 8)

God wishes to create a juxtaposition and highlight two different groups of believers. God rewards us according to our faith and our actions and our intimacy with Him. We will now continue, and examine these two groups of believers . . .

"**Do not harm** the land or the sea or the trees until we put a **seal** on the **foreheads** of the servants of our God." (R7:3)

Not just believers in Christ. But servants of the most High. A servant or **Slave** to God. One who is absolutely committed to God and Jesus. An obedient slave obeys His master. These are dedicated slaves. The stated qualification in this verse - are those who are actual servants of our God.

GOD determines *who* these true servants are . . . Not me; not you; and not your pastor. GOD. God counts, and GOD declares . . . So how *many* are called out as servants of God in this passage?? Remember - God is creating a **juxtaposition**. The question is *why*? A group that can be counted; and one that cannot . . .

Then I heard the **number** of those who were **sealed: 144,000** from all the tribes of Israel. (Rev 7:4)

One Hundred & Forty Four Thousand are **sealed** for a unique purpose and position. The *next* group, although **saved** - are not given this unique seal . . .

After this I looked and there before me was a **great multitude** that no **one could count**, from **every nation**,

*tribe, people and language, standing before the throne and in front of the Lamb. They were wearing white robes and were holding palm branches in their hands. (Rev 7:9)*

These are obviously saved individuals . . . They come from EVERY nation on earth; every tribe (including Jews); and every language! They *worship* God, and are wearing white robes! So - who are they??

The question of WHO these people are - is extremely important! So important - it is ASKED in scripture! John is asked a question . . . The question is given to **Highlight the *juxtaposition*** which God deeply desires for you to realize the importance of . . .

A **Question:**

*Then one of the elders **asked me**, “These in white robes - **who** are they, and **where** did they **come from?**” (Rev 7:13)*

*I answered, “Sir, you know.” (R7:14)*

This *question* was not given to highlight John’s ignorance, or to embarrass him. The question and the creation of this juxtaposition in scripture - is for *our* benefit and edification in Jesus Christ!

And the **ANSWER:**

*. . . And he said, “These are they who have **come out** of the great tribulation; they have washed their robes and made them **white** in the **blood** of the **Lamb**. (Rev 7:14)*

So, the great multitude that could not be counted; they are Christians who experience the coming tribulation. A significant number of individuals. A huge amount. An absolutely HUGE amount of Christians from every people, tribe, nation, and language - who experience the tribulation. An amount so large - that it cannot be counted.

The majority of Christians will go thru, and experience the tribulation. The time of tremendous distress that the World has never before seen, and never will again, has arrived. The **majority** of Christians - will be right in the heart of this tremendous trouble, and have great difficulty.

*. . . There is no rest day or night for those who worship the beast and his image, or for anyone who receives the mark of his name.” This calls for patient endurance on the part of the **saints** . . . Then I heard a voice from heaven say, “Write: **Blessed** are the dead who **die in the Lord** from now on.” “**Yes,**” **says the Spirit**, “they will rest from their labor, for their deeds will follow them.” (Rev 14:11 - 13)*

Scripture has established that the majority of Christians will experience the great tribulation which is coming *upon the whole world to test* **πειράσαι** (to test, tempt, to try to trap; to examine (oneself).) *those who live on the face of the earth.* (R3:10) What of the juxtaposition found in Chapter seven? **Who** are the *One Hundred and Forty-Four Thousand?*

*Then I heard the number of those who were **sealed: 144,000** from all the **tribes of Israel**. From the tribe of Judah 12,000 were sealed, from the tribe of Reuben 12,000, from the tribe of Gad 12,000, from the tribe of Asher 12,000, from the tribe of Naphtali 12,000, from the tribe of Manasseh 12,000, from the tribe of Simeon 12,000, from the tribe of Levi 12,000, from the tribe of Issachar 12,000, from the tribe of*

Zebulun 12,000, from the tribe of Joseph 12,000, from the tribe of Benjamin 12,000. (Rev 7:4 - 8)

First - these are *One Hundred & Forty Four Thousand* - Jews - from all the tribes of Israel. So if you're a believing *Gentile* - you are **excluded**. Right? **Wrong!**

If you are a **believing** (born again) Gentile - you ARE a **JEW!** I am a Jew. I've considered myself a Jew in every way that matters (God's view and *perspective*), for a large number of years.

*If some of the branches have been broken off, and you, though a wild olive shoot, have been grafted in among the others and now share in the nourishing sap from the olive root . . .* (Romans 11:17)

*A man is not a Jew if he is only one outwardly, nor is circumcision merely outward and physical. No, a man is a Jew if he is one inwardly; and circumcision is circumcision of the heart, by the Spirit, not by the written code.* (Romans 2:28 - 29)

See? If you're a true believer in Christ - you are Jewish! Period! Now, I have heard a lot of people state: "Oh, that's what you mean. Yeah, *Ok, right*. But, you not *really* a Jew . . ."

Plus, in today's world; major hatred of the Jews is significantly increasing. Individuals all around in the United States, and elsewhere - who regularly attend a Christian church - are constantly stating: "What right do the Jews have to that land anyway? Why are we supporting them . . . ? They should just let all of those Palestinians have what they want . . ." etc, etc, etc.

Lets just leave Revelation for a moment, and consider something else . . .

GOD *chose* the Jews. They did not deserve it. Just like I do not deserve salvation. But GOD *chose* the Jews. He did so - so that He could make an example of choosing a faithless, undeserving people - and how He would still LOVE them. ANY people or nation He chose - would have acted exactly the same way. But - He had to choose. So He did. He chose the Jews. (*Abraham* - who was NOT faithless.)

Now, because God chose the Jews, and then set His LOVE on them; Satan HATES the Jews. Satan HATES, and absolutely abhors the Jews - because GOD chose them, and LOVES them.

Now, Satan HATES the entire world. EVERY man, woman, and child. Satan HATES. Totally. Because we are made in God's *Image*. So Satan HATES us. If you are a worshiper of Satan - He still HATES you. TOTALLY. He wants only to see you lose your inheritance, and spend ETERNITY - in absolute TORMENT. Satan HATES ALL of mankind, and wants us only to burn forever in Hell.

However, in all of this - Satan has even MORE Hatred for the Jews! Yes, even more. Total, dark black, HATRED for the Jews.

And **REMEMBER** this - if you are a Christian - if you are born again; if you are a **New Creation** in Christ - then **YOU** are a Jew. And Satan HATES all Jews!

Now, get this - Jesus was HATED by the world. Why? Because, He was a Jew, and - the *Son of God*. So, the world and Satan HATED him.

*"You are a child of the devil and an enemy of everything that is right!"* (Acts 13:10)



*This is how we know who the children of God are and who the children of the devil are . . . (1John 3:10)*

*You belong to your father, the devil, and you want to carry out your father's desire. He was a murderer from the beginning . . . (John 8:44)*

*"If the world hates you, keep in mind that it **hated me first**. If you belonged to the world, it would love you as its own. As it is, you do not belong to the world, but I have chosen you out of the world. That is why the world hates you. (John 15:18 - 19)*

*Blessed are you when men hate you, when they exclude you and insult you and reject your name as evil, because of the Son of Man. (Luke 6:22)*

*All men will hate you because of me. (Luke 21:17)*

Now, the World rejoices in itself. People dwell in iniquity, and rejoice in evil. Men carouse in darkness, and rejoice in evil. Because their Father is the devil. But - the devil or Satan - HATES them, and HATES us!

If you are born again; if you are a child of God - then the World HATES you, and Satan HATES you even more! Why do you think Christianity is the most persecuted religion on earth? Why are Jews the most persecuted people on earth? Because they both have been CHOSEN by God. If you are a believer in Christ - you are a JEW, and you *should* LOVE your natural Jewish brethren.

Of course - a true Christian - LOVES unconditionally, and LOVES even His enemies. Because a person who has an intimate relationship with God, wishes ALL people to have that same relationship . . .

My point with the above is that Christians *are* JEWS . . . and I am so 'fed up' with hearing all of these negative and vile remarks with regards to the Jewish people; being stated by various Christians (who *ARE* Jews) - who have absolutely no understanding of the total, and very real absolute spiritual battle they are in - whether they like it or not . . . (Of course, the remarks which I don't appreciate - are just another of the numerous items which must and will happen - during the *End Times* . . . The REALITY - is that it is only going to get worse.)

Getting back to Revelation and chapter seven . . .

These are *One Hundred & Forty Four Thousand* - Jews - from all the tribes of Israel. And if you are a believer and follower of Christ - than you are a member of a tribe of Israel.

*Second* - this group is extremely SMALL, and is very countable. The world population is over 7 Billion; and this group barely hits even **0.002%** of the population! Most cities throughout the world - have significantly more people - in just one city.

*Third* - this very small group of *believers* do not experience the great tribulation!

The juxtaposition which God created here in these verses - emphasized a very small group of believers; and a large, huge, uncountable group of believers - who DID come out of the great tribulation.

*Fourth* - the number herein given - is *symbolic*. This group of believers could actually number *less*; or could number *more*. The number given is symbolic. It is given for two purposes: to emphasize for the believer that this special group is very small; and to assist with the proper identification of just *who* these

believers are . . .

This blessed group of believers center around the number **Twelve**. Twelve and *multiples* of it. Numbers have meaning in scripture . . . *Seven* is the number of *fullness* and completeness in God. We have *seven* days in a week; God *rested* on the *seventh* day; we have *seven seals*, *seven lampstands*, *seven spirits of God*, *seven thunders*, *seven eyes* of the Lamb, *seven requests* to listen to the Spirit of God . . . etc, etc.

**Twelve** is *final* or absolute total **Completeness**. *Twelve* includes the *twelve apostles* of the Lamb; *twelve months* in a year; *twelve rulers*; *twelve stone pillars*; *twelve stones* (Ephod); *twelve loaves of bread*; *twelve gold dishes*; *twelve thousand horses*; *twelve bulls*; *twelve lions*; *a crown of twelve stars*; *twelve crops of fruit*; the *Bride of Christ* has *twelve gates* and *twelve angels* . . .

*Do you think I cannot call on my Father, and he will at once put at my disposal more than twelve legions of angels? But how then would the Scriptures be fulfilled that say it must happen in this way? ”*

(Matthew 26:53 - 54)

Various numbers do have meaning in scripture! [There is no doubt a proper sequence of numbers representing the creation order 7, the ritual 3, and the unique 1. Larger numbers such as 40, 80, **120**, and **1,000** also are used with significance.] (The Zondervan Pictorial Encyclopedia of the Bible, Pradis CD-ROM:Articles/N/Number/II. OT Biblical numbers/E. Symbolic and mystical numbers., Book Version: 4.0.1)

*Fifth* - these believers who are called out of the twelve tribes of Israel - receive a special seal. We have seen that this is not a salvation seal . . . So what type of seal is it? This seal carries a couple of meanings. It is a seal of **authority**. And when a **Bride** is  *betrothed* - she *receives* a **seal** of the betrothal. Commonly - this is in the form of a ring; and in some cultures could be a dowry. The **marriage seal** may take many forms, and may be anything which is agreed upon. And ages ago - was even described as such:

. . . “Let me find favor in your eyes, and I will give you whatever you ask. Make the **price for the bride** and the **gift** I am to bring as great as you like, and I’ll **pay whatever** you ask me. Only give me the girl as my **wife**.” Because their sister Dinah had been defiled, Jacob’s sons replied deceitfully as they spoke to Shechem and his father Hamor. They said to them, “We can’t do such a thing; we **can’t give our sister** to a man who is not circumcised. That would be a disgrace to us. We will **give our consent** to you on **one condition only**: that you become like us by **circumcising** all your males. (Genesis 34:11 - 15)

**Who** are the **144,000** from the **twelve** tribes of Israel? This is the **BRIDE** of **CHRIST!** **Hallelujah!**

A husband protects his wife. He keeps her from harm.

. . . *Jesus Christ laid down his life for us* . . . (1John 3:16)

*“I am the good shepherd. The good shepherd lays down his life for the sheep.* (John 10:11)

*Husbands, love your wives, just as Christ loved the church and gave himself up for her* . . . (Ephesians 5:25)

*Since you have kept my command to endure patiently, I will also keep you from the hour of trial that is going to come upon the whole world to test those who live on the earth.* (R3:10)

Now the **144,000** from the **twelve** tribes of Israel - do not experience the great tribulation. That is fairly obvious from the **juxtaposition** which is described throughout chapter seven. We will now look at other

scriptures in Revelation, to further reveal that these **144,000** (symbolic number) constitute the Bride of Christ.

*Then I looked, and there before me was the Lamb, standing on Mount Zion, and with him 144,000 who had his name and his Father's name written on their foreheads. And I heard a sound from heaven like the roar of rushing waters and like a loud peal of thunder. The sound I heard was like that of harpists playing their harps. And they sang a new song before the throne and before the four living creatures and the elders. No one could learn the song except the 144,000 who had been redeemed from the earth. These are those who did not defile themselves with women, for they kept themselves pure. They follow the Lamb wherever he goes. They were purchased from among men and offered as firstfruits to God and the Lamb. No lie was found in their mouths; they are blameless.* (Rev 14:1 - 5)

What is the meaning of the phrase **Mount Zion??** In English - the definition of the word **Zion** is **Citadel**. Per [*The American Heritage Dictionary of the English Language* (1973); pg 245]; **Citadel: A Fortress in a commanding position in or near a city.** [2] Any **Stronghold** or fortified place; a bulwark. [3] The heavily plated central structure of a war vessel.

The Greek {G4994} word translated as **Zion Σιὼν** (Zion, "{citadel}") occurs precisely **seven** times in the New Testament. In the NT; this is also the **ONLY** word which may be translated as **Zion**. If you will recall; **seven** is the number of **Fullness** and **Completeness** in God.

**Zion** means Citadel. A Citadel is a **Fortress** or **Stronghold**.

. . . "The **LORD** is my **rock** {H6152}, my **fortress** and my deliverer; my **God** is my **rock** {H7446}, in whom I take refuge, my shield and the horn of my salvation. He is my **stronghold**, my refuge and my savior - from violent men you save me. (2Samuel 22:2 - 3)

The **LORD** reigns forever; he has established his **throne for judgment**. He will judge the world in righteousness; he will govern the peoples with justice. The **LORD** is a **refuge** for the oppressed, a **stronghold** in times of trouble. (Psalms 9:7 - 9)

The **LORD** is my **rock** {H6152}, my **fortress** and my deliverer; my **God** is my **rock** {H7446}, in whom I take refuge. He is my shield and the horn of my **salvation**, my **stronghold**. (Psalms 18:2)

. . . The **LORD** is the **stronghold** of my life - of whom shall I be afraid? (Psalms 27:1)

The **righteous** will see and fear; they will laugh at him, saying, "Here now is the man **who did not** make **God his stronghold** but trusted in his great **wealth** . . . (Psalms 52:6 - 7)

He is my loving **God** and my **fortress**, my **stronghold** and my deliverer, my **shield**, in whom I take **refuge** . . . (Psalms 144:2)

The **LORD** will rule over them **in Mount** {H2215} **Zion** from that day and **forever**. As for you, O watchtower of the flock, O **stronghold** of the **Daughter of Zion** . . . (Micah 4:7 - 8)

The **LORD** is the **strength** of his people, a **fortress** of salvation for his **anointed one**. (Psalms 28:8)

"Be still, and know that **I am God**; I will be exalted among the nations, I will be exalted in the earth."  
The **LORD Almighty** is with us; the **God of Jacob** is our **fortress**. (Psalms 46:10 - 11)

He alone is my **rock** {H7446} and my salvation; he is my **fortress**, I will never be shaken. (Psalms 62:2)

. . . you are my **rock** {H6152} and my **fortress**. (Psalms 71:3)

But the **LORD** has become my **fortress**, and my **God the rock** {H7446} in whom I take refuge. (Psalms 94:22)

He who fears the **LORD** has a secure **fortress** . . . (Proverbs 14:26)

You have forgotten **God** your **Savior**; you have not remembered **the Rock** {H7446}, **your fortress** . . .  
(Isaiah 17:10)

. . . “Who of us can dwell with the **consuming fire**? Who of us can dwell with everlasting burning?” He who **walks righteously** and speaks what is right, who **rejects** gain from **extortion** and keeps his hand from accepting bribes, who stops his ears against plots of murder and **shuts his eyes** against **contemplating evil** - this is the **man** who will **dwell on the heights**, whose refuge will be the **mountain** {H6152} **fortress** . . .  
(Isaiah 33:14 - 16)

For the **LORD** your God is a **consuming fire** . . . (Deuteronomy 4:24)

for our “**God is a consuming fire**.” (Hebrews 12:29)

From the above, it is easily seen that God is viewed as a **Fortress** and a **Stronghold**. Notice also - that God is also identified with being a **Rock** or a **Mountain**; and **dwelling on the heights**. The Hebrew words used in these verses for **Rock** and **Mountain** are the following:

**סֶלֶעַ** {H6152} (rock, stone; rock formation: cliff, crag, by extension: stronghold, fortress; God as a “**Rock**” focuses on stability, faithfulness, and protection)

**צוּר** {H7446} (rock, stone mass, rocky crag; a title of God, with a focus of stability, and possibly as a place of security and safety)

**הַר** {H2215} (hill, mountain, range (of hills, mountains); referring to low hills as well as high mountains)

Also, I find it interesting - that the very *first* instances of **סֶלֶעַ** and **צוּר** occurring in scripture; are directly foretelling **Jesus** as God and the Christ.

They were all baptized into Moses in the cloud and in the sea. They all ate the same spiritual food and drank the same spiritual drink; for they drank from the **spiritual rock** that accompanied them, and that **rock was Christ**. Nevertheless, God was not pleased with most of them . . . (1Corinthians 10:2 - 5)

“Take the staff, and you and your brother Aaron gather the assembly together. Speak to that **rock** {H6152} before their eyes and it will **pour out its water**. You will bring water out of the **rock** {H6152} for the community so they and their livestock can drink.” (Numbers 20:8 [first instance])

I will stand there before you by the **rock** {H7446} at Horeb. Strike the **rock**, {H7446} and **water will come out** of it for the people to drink.” So Moses did this in the sight of the elders of Israel. (Exodus 17:6 [first instance])

*Be appalled at this, O heavens, and shudder with great horror,” declares **the LORD**. “My people have committed two sins: They have forsaken me, the **spring of living water** . . . (Jeremiah 2:12 - 13)*

*Jesus answered her, “If you knew the **gift of God** and **who** it is that asks you for a drink, you would have asked him and he would have given you **living water**. ” (John 4:10)*

*On the last and greatest day of the Feast, **Jesus** stood and said in a loud voice, “If anyone is **thirsty**, let him **come to me and drink**. Whoever believes in me, as the Scripture has said, **streams of living water** will flow from within him.” (John 7:37 - 38)*

God is identified as a **Fortress** and a **Stronghold**. God and **Jesus** are identified as a **Rock**. God dwells in the **heights** - on a **Holy Mountain**. And the word **Zion** indicates a citadel. The word **Zion** is also used to reference a Holy City - Jerusalem; and **Mount Zion** - one specific section of Jerusalem - the SE section. And the word **Zion** is used in the phrase **daughter of Zion**. And the **daughter of Zion** is specifically referenced as a **Virgin** . . .

[The SE hill of Jerusalem; poetically, the entire city.] (The Zondervan Pictorial Encyclopedia of the Bible, Pradis CD-ROM:Articles/Z/Zion, Book Version: 4.0.1)

*Nevertheless, David captured the fortress of **Zion**, the **City of David**. (2Samuel 5:7)*

*. . . So **David** went down and brought up the **ark of God** from the house of Obed-Edom to the **City of David with rejoicing**. (2Samuel 6:12)*

*“I, **Jesus**, have sent . . . I am the **Root** and the **Offspring** of David . . . ” (Rev 22:16)*

*. . . ‘The **Virgin Daughter of Zion** despises you and mocks you. The **Daughter of Jerusalem** tosses her head as you flee. (2Kings 19:21)*

*that I may declare your **praises** in the **gates** of the **Daughter of Zion** and there rejoice in your **salvation**. (Psalms 9:14)*

*This day they will halt at Nob; they will **shake their fist** (cursed the name of God (R16:9)) at the **mount** of the **Daughter of Zion**, at the **hill of Jerusalem**. (Isaiah 10:32)*

*Send **lambs as tribute** to the **ruler** of the land, from Sela, across the desert, to the **mount** of the **Daughter of Zion**. (Isaiah 16:1)*

*The **LORD** has made **proclamation** to the ends of the earth: “Say to the **Daughter of Zion**, ‘**See, your Savior comes!** See, his reward is with him, and his recompense accompanies him.’ ” (Isaiah 62:11)*

*Send forth your **light** and your **truth**, let them guide me; let them bring me to your **holy mountain**, to the place where **you dwell**. (Psalms 43:3)*

*Great is the **LORD**, and most worthy of praise, in the city of our **God, his holy mountain**. It is beautiful in its loftiness, the joy of the whole earth. Like the utmost heights of Zaphon is **Mount Zion**, the **city** of the **Great King**. (Psalms 48:1 - 2)*

*He has set his **foundation** on the **holy mountain**; the **LORD** loves the **gates of Zion** more than all the*



*dwelling of Jacob.* (Psalms 87:1 - 2)

*Exalt the LORD our God and worship at his holy mountain, for the LORD our God is holy.* (Psalms 99:9)

*And in that day a great trumpet will sound. Those who were perishing in Assyria and those who were exiled in Egypt will come and worship the LORD on the holy mountain in Jerusalem.* (Isaiah 27:13)

*This is what the LORD says: "I will return to Zion and dwell in Jerusalem. Then Jerusalem will be called the City of Truth, and the mountain of the LORD Almighty will be called the Holy Mountain."* (Zechariah 8:3)

Let us summarize ALL of the above scriptures. **Zion** is a **Fortress** (God) or **Stronghold**. **God** is also referenced as a **Rock**; who dwells on a **Holy Mountain**. The **daughter of Zion** is declared to be a **virgin**; and God states that He is a consuming fire, and who can dwell with Him in the Heights. It is stated that only the righteous - those who shut their eyes against even thinking about evil - will dwell with God in the Heights.

In various world cultures, we have the common phrases: "We are the **children of God**" & "I am a **child of God**." The phrase which Jesus used to describe His relationship was: "**Son of God**". That phrase is a term for the positional authority, divinity and equality with God - which Jesus held even as a man. With Zion, we see that we have a phrase which is used *only* with **Zion**. That is, the phrase: "**Daughter of Zion**". And we now know that **Zion** is a reference to **God**; and **Mount Zion** is a reference to the **dwelling place** of God; and of God's protective aspect towards those He loves.

We are discussing the twelve tribes of Israel; and in particular - the **144,000**. I have stated that these constitute the Bride of Christ. God, is looking for a Bride or Wife for Himself - or for His Son; Jesus. Jesus refers to himself as the *Son of God*; and now we have the "*Daughter of Zion*" or in other words: The *Daughter of God* . . . or a **BRIDE** for the Lamb. (R21:9)

From the opening of chapter *Seven*; where the 144,000 are introduced - and a juxtaposition created - we next clearly see the same 144,000 at the beginning of chapter *Fourteen*. Now that we have reviewed the above scriptures . . .

*Then I looked, and there before me was the Lamb, standing on Mount Zion, and with him 144,000 who had his name and his Father's name written on their foreheads. And I heard a sound from heaven like the roar of rushing waters and like a loud peal of thunder. The sound I heard was like that of harpists playing their harps. And they sang a new song before the throne and before the four living creatures and the elders. No one could learn the song except the 144,000 who had been redeemed from the earth. These are those who did not defile themselves with women, for they kept themselves pure. They follow the Lamb wherever he goes. They were purchased from among men and offered as firstfruits to God and the Lamb. No lie was found in their mouths; they are blameless.* (Rev 14:1 - 5)

A tremendous amount exists in those few opening verses of Chapter *fourteen*.

*First* - we see that the **144,000** are *standing* on **Mount Zion** (God) with the **Lamb** or *Jesus*.

Now scripture assigns various names to Jesus or the Christ. Just as scripture assigns various names to God, the Father. One of those names which is a reference to Jesus; and His sacrifice for us - is the *Lamb*. The **Lamb of God**. The *Lamb* shed his **blood** for us, and gave His life for us. (R1:5; R5:8,9)

*Second* - in this prophecy - every time it uses the word **Wife**, or **Bride** - this is ALWAYS in reference to the word **Lamb** or *Jesus*. The common phrase *Bride of Christ* is essentially the same as: *Wife of the Lamb*. It carries with it identical meanings. But the *phrase* **Bride of Christ** - does **not exist** in all of scripture. The meaning and concept of the phrase **Bride of Christ** is clearly seen in various verses; such as John 3:28 - 29; and statements Jesus made with regards to *Wedding Banquets & Bridegrooms*.

Chapter fourteen opens not only with the **144,000** standing on God - but they are also standing *next* to the **Lamb**. The 144,000 are the **ONLY** group identified in this prophecy - as having not only Jesus' or the **Lamb's name** written on their foreheads - but **ALSO** the **Father's name**.

In **ALL** of Revelation - this is the **ONLY** group identified with being given the Father's name. Of course I say that - knowing and understanding that the 'church' of *Philadelphia* - is also given the Father's name.

. . . *I will write on him the name of my God* . . . (Rev 3:12)

*Philadelphia* (*love of brother/sister*) - I stated in discussion on Chapter three - was the first description of the *Bride of Christ*. Or the **Wife of the Lamb**. The church of *Philadelphia*, and the **144,000** - are one and the same. The same group of individuals.

*Third* - we have a great sound of **wonderful music**. God gives us living water; and we have the sound of the roar of **rushing waters**, with **Harps** being played. And then they sing a song - which they alone are allowed to sing! A glorious new song. A new life, a new start. A wedding is often referred to as *starting a new life together*. And at weddings - the *Bride and Bridegroom* - frequently have their own song. Sometimes they sing it to one another; other times they have someone play it for them . . . But *Bride and Bridegroom* - often have 'their song'. Same with these verses. A loud, joyful celebration; with the *Bride and the Bridegroom* - having 'their' song. Only a song *they* are allowed to sing.

*Let Israel rejoice in their Maker; let the people of Zion be glad in their King. Let them praise his name with dancing and make music to him with tambourine and harp.* (Psalms 149:2 - 3)

*Fourth* - then we have the statement that they did not **defile themselves with women**, for they kept **themselves pure**. And they *follow the lamb wherever he goes*.

In scripture, and even in today's life - the wife is generally expected to go - wherever her husband goes . . . In many places of the world - marriage vows include the words: "*In sickness and in health . . . till death do us part.*"

Now the above words are not: until we decide to get divorced. No, in marriage - two people were to become **ONE**, and they were to remain so . . . and the wife and the man would live together - being united in purpose and many thoughts; until death dissolved their union.

"*Son of man, with one blow I am about to take away from you the delight of your eyes. Yet do not lament or weep or shed any tears.*" (Ezekiel 24:16)

*Some Pharisees came and tested him by asking, "Is it lawful for a man to divorce his wife?" "What did Moses command you?" he replied. They said, "Moses permitted a man to write a certificate of divorce and send her away." "It was because your hearts were hard that Moses wrote you this law," Jesus replied. "But at the beginning of creation God 'made them male and female.' 'For this reason a man*

will leave his father and mother and be *united to his wife*, and the *two will become one flesh*.’ So they are no longer two, but *one*. Therefore what *God has joined together, let man not separate*.” (Mark 10:2 - 9)

So the Bride is with her husband - the Lamb of God. And goes with Him - wherever He goes.

And a man who is marrying the woman he loves - desires for her to be a virgin. For her not to have been being intimate with various men . . . So too - with God! He is looking for intimacy with us, and with His Bride. So Zion is declared to be a virgin; and so too - are the 144,000 declared to be virgins! They have waited on their bridegroom, and *kept themselves pure*.

The statement: “*did not defile themselves with women*”; is not in ANY way stating that being *married* is a defilement. For the marriage bed is undefiled.

*Marriage should be honored by all, and the marriage bed kept pure* . . . (Hebrews 13:4)

*Marriage is honourable in all, and the bed undefiled* . . . (Hebrews 13:4 KJV)

Neither is it stating that all of the **144,000** (symbolic number) are *males!* **No**, a *marriage statement* is being made here at the beginning of chapter *Fourteen*; and the fact that the Bride is pure and Holy is being declared. These people are declared by God to be *virgins* - they are the *Daughter of Zion*; and they have just been married to the Lamb! The phrase “*defile themselves with women*” is given for two reasons:

1. Because these verses open up discussing the *Wife of the Lamb*. So the verses are stating that she is pure, and undefiled.
2. As believers in Christ - if we wish to be part of the Bride; and not experience the great tribulation; if we wish to be part of that select group who are found WORTHY to be the wife of the Lamb - then we are required to be intimate with God. To put off all of the pleasures and distractions of this world - which so easily entangle us, and which encourage us not to be focused on God, and listening to our teacher - Mr. **Holy Spirit!**

The **144,000** have been focused on, and *intimate* with God. They **LOVE** Jesus, and **OBEY** His commands. They **LOVE** God; and they **LOVE their fellow brethren**, and the people all around them - who hate them. They have decided not to be caught up in this world - but to be totally **consumed by God** - who is **a consuming fire**. They allowed God to heat them up, and **refine** them. They allowed themselves to become so intimate with God - that they became absolutely pure . . . And so God consumes them; and they are pure and holy; and they are found worthy to be the *Wife of the Lamb*.

*Therefore, since we are surrounded by such a great cloud of witnesses, let us throw off everything that hinders and the sin that so easily entangles, and let us run with perseverance the race marked out for us.* (Hebrews 12:1)

*You were taught, with regard to your former way of life, to put off your old self, which is being corrupted by its deceitful desires; to be made new in the attitude of your minds; and to put on the new self, created to be like God in true righteousness and holiness. Therefore each of you must put off falsehood and speak truthfully* . . . (Ephesians 4:22 - 25)

*At one time we too were foolish, disobedient, deceived and enslaved by all kinds of passions and pleasures*. . . (Titus 3:3)

But mark this: There will be terrible times in the last days. People will be *lovers of themselves*, lovers of *money*, boastful, *proud*, abusive, disobedient to their parents, *ungrateful*, unholy, *without love*, *unforgiving*, slanderous, without self-control, brutal, *not lovers of the good*, treacherous, rash, conceited, *lovers of pleasure* rather than lovers of God - *having a form of godliness* but *denying its power*. (2Timothy 3:1 - 5)

*Fifth* - these **144,000** are declared to be *FirstFruits*. Jesus was the *firstfruit and first born* for our *salvation*. And so is His Bride. She has made herself ready, and has *clothed herself in righteousness*. She is *Blameless*. FirstFruits, and the sacrifices made for atonement, and celebration of various feasts and harvests - using Bulls, and Lambs, etc. were always to be without any Blemish; and had some age restrictions. *Perfection*, a Holy virgin with *sufficient oil*. Note also that they were *purchased* or *redeemed* from among men. The first offspring from any womb was required to be redeemed, or purchased. The **144,000** were *purchased* by Jesus; dedicated to serve God, and given by God to the High Priest of the *first born* of the *resurrection* of the dead - Jesus the ultimate *High Priest* - to be *His*. The best of the best was given to the Priests who served God.

Just as God made Adam, the first man; and then took a rib from Adam, and made Eve - the first woman; as a wife for Adam - so too Jesus saved and redeemed us all; and God has taken the best of the best from the Church; and made a Wife for the Lamb. Eve was taken from the body of Adam; and the Bride is taken from the Body of Christ - the Church.

. . . They were *purchased* from among men and offered as *firstfruits* to God and the Lamb. *No lie* was found in their mouths; they are *blameless*. (Rev 14:4 - 5)

But *Christ* has indeed been *raised from the dead*, the *firstfruits* of those who have fallen asleep. For since death came through a man, the *resurrection of the dead* comes also through a man. (1Corinthians 15:20 - 21)

The animals you choose must be *year-old males without defect*, תָּמִים (without defect, blameless, perfect) and you may take them from the sheep or the goats. (Exodus 12:5)

Your lamb shall be *without blemish*, a male of the *first year* . . . (Exodus 12:5 KJV)

Celebrate the Feast of Harvest with the *firstfruits* of the *crops* you sow in your field. "Celebrate the Feast of Ingathering at the end of the year, when you gather in your crops from the field. "Three times a year all the men are to appear before the Sovereign LORD. "Do not offer the blood of a sacrifice to me along with anything containing yeast. "The fat of my festival offerings must not be kept until morning. "Bring the best of the *firstfruits* of your soil to the house of the LORD your God. "Do not cook a young goat in its mother's milk. (Exodus 23:15 - 19)

"I give you all the *finest olive oil* and all the *finest new wine* and grain they give the LORD as the *firstfruits* of their harvest. All the *land's firstfruits* that they bring to the LORD will be *yours* . . . (Numbers 18:12 - 13)

The *first offspring* of every *womb*, both *man and animal*, that is offered to the *LORD* is yours. But you must *redeem* every *firstborn son* and every *firstborn male* of *unclean animals*. (Numbers 18:15)

"But you *must not redeem* the *firstborn of an ox*, a *sheep or a goat*; they are *holy*. *Sprinkle their blood* on the altar . . . (Numbers 18:17)

He said to Aaron, “Take a bull calf for your sin offering and a ram for your burnt offering, **both without defect**, and present them before the LORD. Then say to the Israelites: ‘Take a male goat for a sin offering, a calf and a lamb - **both a year old and without defect** - for a burnt offering, and an ox and a ram for a fellowship offering to sacrifice before the LORD, together with a grain offering mixed with oil. For today the LORD will appear to you.’ ” (Leviticus 9:2 - 4)

“On the eighth day he must bring **two male lambs** and one **ewe lamb a year old**, each **without defect**, along with three-tenths of an ephah of fine flour **mixed with oil** for a grain offering, and one **log of oil**. (Leviticus 14:10)

. . . ‘If any of you - either an Israelite or an alien living in Israel - **presents a gift** for a burnt offering to the LORD, either to fulfill a vow or as a freewill offering, you must present a **male without defect** from the cattle, sheep or goats in order that it may be **accepted** on your behalf. **Do not** bring **anything** with a **defect**, because it will **not be accepted** on your behalf. When anyone brings from the herd or flock a fellowship offering to the LORD to fulfill a special vow or as a freewill offering, **it must be without defect or blemish** to be acceptable. (Leviticus 22:18 - 21)

You may, however, present as a **freewill offering** an ox or a sheep that is deformed or stunted, but it will **not be accepted in fulfillment of a vow**. (Leviticus 22:23)

When a calf, a lamb or a goat is born, it is to remain with its mother for **seven** days. From the **eighth** day on, it will be **acceptable as an offering** made to the LORD by fire. (Leviticus 22:27)

On the day you **wave the sheaf**, you must **sacrifice as a burnt offering** to the LORD **a lamb a year old without defect**, together with its grain offering of two - tenths of an ephah of fine flour **mixed with oil** . . . (Leviticus 23:12 - 13)

“At that time the **kingdom of heaven** will be like ten **virgins** who took their **lamps** and went out to meet the bridegroom. Five of them were foolish and five were wise. The foolish ones took their lamps but did **not take any oil** with them. The **wise**, however, **took oil in jars** along with their lamps. The bridegroom was a long time in coming . . . The **virgins** who were **ready** went in with him to the wedding banquet . . . (Matthew 25:1 - 5, 10)

**FIRSTBORN.** (Heb. *bekhôr*, Gr. *prototokos*). The Hebrew word is used chiefly of men, but is used also of animals ([Exod 11:5](#)). It appears that man early felt that God had the first claim on animals ([Gen 4:4](#)). Among the ancestors of the Hebrews the first-born offspring of men and animals were sacrificed to the deity. Because the first-born of the Israelites were preserved at the time of the first Passover, every firstborn male of man and beast became consecrated to God ([Exod 13:2; 34:19](#)). The beasts were sacrificed, while the men were redeemed ([Exod 13:13, 15; 34:20](#); cf. [Lev 27:6](#)). At Sinai the Levites were substituted for the Israelite firstborn ([Num 3:12, 41, 46; 8:13-19](#)). On the thirtieth day after birth the father brought his firstborn son to the priest and paid five shekels to redeem him from service in the temple (cf. [Luke 2:27](#)).

Among the Israelites the first-born son possessed special privileges. He succeeded his father as the head of the house and received as his share of the inheritance a double portion. Israel was the Lord’s firstborn ([Exod 4:22](#)) and was thus entitled to special privileges, as compared with other peoples. Jesus Christ is described as the firstborn ([Rom 8:29; Col 1:15; Heb 1:6](#)), an application of the term that may be traced back to [Psalm 89:27](#), where the Messiah is referred to as the firstborn of God. - SB



**FIRSTFRUITS** (Heb. *re'shîth, bikkûrîm*, Gr. *aparche*). In acknowledgment of the fact that all the products of the land came from God, and to show thankfulness for his goodness, Israelites brought as an offering a portion of the fruits that ripened first. These were looked on as a pledge of the coming harvest. Such an offering was made both on behalf of the nation ([Lev 23:10, 17](#)) and by individuals ([Exod 23:19; Deut 26:1-11](#)). These firstfruits went for the support of the priesthood.

Jesus is the firstfruits of all who die in faith; that is, the resurrection of believers is made possible and is guaranteed by his resurrection ([1 Cor 15:20](#)). Believers, in turn, are “a kind of firstfruits” of all that God created ([James 1:18](#)); creation will share in the redemption of the children of God ([Rom 8:19-21](#)).] (*New International Bible Dictionary*, Pradis CD-ROM:Articles/F/Firstborn. through Articles/F/Firstfruits, Book Version: 5.1.50)

Possibly - even after all of the above scriptures; you still do not believe or understand that the **144,000** coming out of the **twelve tribes** of Israel; constitute the *Bride of Christ*, or the **Wife of the Lamb**.

So let us look at a couple more scriptures, and remember a couple of previously discussed points . . .

With regards to the church of Philadelphia - Jesus made these statements:

1. He would **keep them from the hour of trial** that is coming to test those who live on the earth.
2. They would be a **pillar in the temple of God**.
3. The name of **God, the Father** - would be written on them.
4. The name of **God's city** - the *new Jerusalem* would be written on them.
5. Jesus has a special *intimate* name that only *He knows*. ([R19:12](#)) And **Jesus' new name** would be written on them.

The **144,000** are referenced coming out of the *twelve tribes* of Israel. **Twelve** means final and total completeness. A *juxtaposition* is created and emphasized in scripture (*chapter seven*) - between the 144,000 and those who were too **numerous** to be counted; and who came out of the great tribulation.

Chapter *Fourteen* continues with the *revealing* of the 144,000 and states they are standing on **Mount Zion**; with the Lamb standing next to them . . . And then the verses discuss the 144,000 in language referencing marriage.

Let's take a brief look at chapter *Twenty-One*. The main *subject* of chapter *Twenty-One*; is **clearly** the *Bride*, or the **Wife of the Lamb**.

*I saw the Holy City, the new Jerusalem, coming down out of heaven from God, prepared as a bride beautifully dressed for her husband. And I heard a loud voice from the throne saying, "Now the dwelling of God is with men, and he will live with them . . ."* ([Rev 21:2 - 3](#))

*One of the seven angels . . . came and said to me, "Come, I will show you the bride, the wife of the Lamb." And he carried me away in the Spirit to a mountain great and high, and showed me the **Holy City, Jerusalem**, coming down out of heaven from **God**. It shone with the *glory of God*, and its brilliance was like that of a very **precious jewel**, like a jasper, **clear as crystal**. It had a great, high wall with twelve gates, and with **twelve angels at the gates**. On the gates were written the **names of the twelve tribes** of*

Israel. There were *three gates* on the east, *three* on the north, *three* on the south and *three* on the west. The wall of the *city had twelve foundations*, and on them were the *names* of the *twelve apostles* of the *Lamb*. The angel who talked with me had a *measuring rod of gold* to measure the *city*, its *gates* and its *walls*. The city was laid out like a *square*, as long as it was wide. He measured the city with the rod and found it to be *12,000 stadia in length*, and as *wide and high as it is long*. He measured its *wall* and it was *144 cubits thick*, by man's measurement, which the angel was using. The wall was made of *jasper*, and the *city of pure gold, as pure as glass*. (Rev 21:9 - 18)

The *twelve gates were twelve pearls*, each *gate* made of a *single pearl*. The great *street* of the city was of *pure gold, like transparent glass*. (Rev 21:21)

\*\*\*\*\*

King David requests mercy and deliverance - so that he may declare God's praises in the *gates* of the *Daughter of Zion*, and there rejoice in God's salvation. And *God declares* that He *loves* the *gates of Zion*.

. . . *Have mercy and lift me up from the gates of death, that I may declare your praises in the gates of the Daughter of Zion and there rejoice in your salvation*. (Psalms 9:13 - 14)

He has set his *foundation on the holy mountain*; the *LORD loves* the *gates of Zion* more than all the dwellings of Jacob. *Glorious things are said of you, O city of God* . . . (Psalms 87:1 - 3)

For he was looking forward to the *city with foundations*, whose *architect and builder is God*. (Hebrews 11:10)

. . . *fellow citizens with God's people and members of God's household, built on the foundation of the apostles and prophets, with Christ Jesus himself as the chief cornerstone*. (Ephesians 2:19 - 20)

. . . "See, I lay a *stone in Zion*, a chosen and *precious cornerstone*, and the one who trusts in him will never be put to shame." (1Peter 2:6)

"Again, the *kingdom of heaven* is like a merchant looking for *fine pearls*. When he found one of *great value*, he went away and *sold everything* he had and *bought it*. (Matthew 13:45 - 46)

Here we go again . . . We go to chapter 21; discussing the *New Jerusalem*, or the *Wife of the Lamb* - and I toss around scriptures referencing the *Daughter of Zion* . . . who God makes like the "Son of God." She is the *Daughter of Zion*. The Lamb, or Jesus - will not be unequally joined, or yoked.

Members of the church of Philadelphia are not going to experience the great tribulation. And obviously - the *Wife of the Lamb* - is not going to experience the great tribulation. Most of the church will - but not the Wife! Chapter Twenty-One discusses the *Wife of the Lamb*. The Wife of the Lamb is almost the entire chapter.

But, the Wife, or the new Jerusalem - is given specific *measurements* in chapter 21. We are given the symbolic dimensions of the New City of God; or the *Wife of the Lamb*. Now, those dimensions - are PRECISELY the exact, and same dimensions of the *144,000*.

1. The Wife has twelve gates, with the names of the twelve tribes of Israel written on those gates.

- 1a. The 144,000 come out of the twelve tribes of Israel.
2. The Holy City, or Wife of the Lamb - is now part of a Mountain, Great and High.
  - 2a. The 144,000 are seen standing on Mount Zion.
3. The Wife shines with the Glory of God.
  - 3a. The 144,000 are the Daughter of God (Zion).
4. An Angel *measures* the Holy City - using a rod of very pure, and refined gold.
  - 4a. An Angel counts or measures the twelve tribes of Israel.
5. The lengths of the Holy City are all equal; and found to be 12,000 stadia.
  - 5a. Out of the twelve tribes of Israel - 12,000 are called out from each tribe.
6. The walls of the Holy City rest on *twelve* apostles, and are measured to be 144 cubits thick.
  - 6a. The *twelve* tribes constitute 144 thickness. ( $12 \times 12 = 144$ )
7. The Holy City has twelve Gates. Each gate is made from a single pearl, which has the name of one of the twelve tribes of Israel written on it.
  - 7b. Jesus declared God was looking for a pearl of great price. Each tribe is declared to be a pearl.

Let us look at the dimensions of the city in a slightly different manner. I am not artistically inclined - so please excuse the crudeness of the drawing. It slightly represents the dimensions of the Wife of the Lamb.

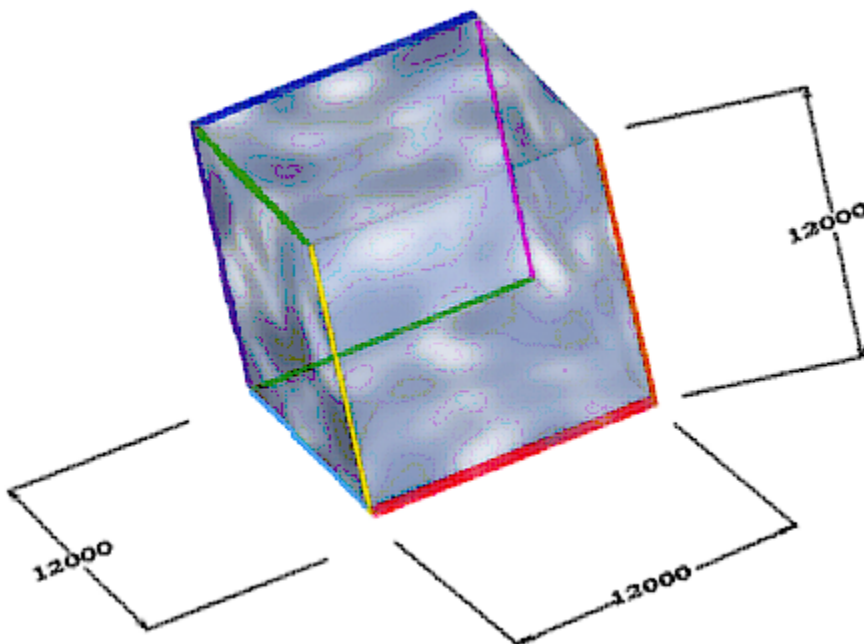

The *Wife* of the *Lamb* or the *Daughter of Zion* is described as being *laid out like a square . . . and as wide and high as it is long*. She has twelve *gates*, and *twelve* foundations. A cube is a square - by definition - which has *six* faces or sides - but *Twelve edges*. In the simple representation above - I have highlighted *nine* of the edges. **Twelve edges** exist.

God never asks us in the Revelation prophecy to attempt to obtain square footage, or some cubic volume measurement. God constantly asks us in Revelation - to learn to Hear the Spirit of God. To develop our ear to Hear God.

If one attempts to obtain the *square* 'footage' of the City - we arrive at the following:

$$12,000 \times 12,000 = 144,000,000$$

One Hundred & Forty Four Million . . . an interesting number - but somewhat pointless for the significance of what God and the Spirit are declaring.

We open chapter Seven - Counting. Not multiplying, or squaring, or obtaining cubic volume. A number which could be counted; and one which could not.

The dimensions of the city are declared to be 12,000 stadia. Each tribe is 12,000 *counted* out, for a total of **144,000**

Obviously - if we count *each* of the TWELVE edges or *foundations* of the Holy City . . .

$$12,000 + 12,000 + 12,000 + 12,000 + 12,000 + 12,000 + 12,000 + 12,000 + 12,000 + 12,000 + 12,000 + 12,000 = 144,000$$

We could also state this as: 12 (tribes) x 12,000 (per tribe) = **144,000**

The city has twelve foundations - with each foundation having the name of one of the apostles of the Lamb written on it. Each of the walls and gates are resting on a foundation. And each gate has one of the names of the twelve tribes of Israel written on it . . .

The thickness of each wall is declared to be **144** cubits.

Twelve tribes form the thickness, resting on the twelve apostles.

$$12 + 12 + 12 + 12 + 12 + 12 + 12 + 12 + 12 + 12 + 12 + 12 = 144$$

**Twelve** - the number of total and absolute completeness and finality in God.

Do you know where *any* number which can be translated as TWELVE *first* appears in scripture?? It is found at: *Genesis 14:4* or in a way - **144**

I sincerely hope that you now fully understand - that many, many Christians are going to experience the great tribulation. A very few, select chosen ones - who OBEY God, and TOTALLY LOVE God - are preserved (or kept from) the great tribulation. Jesus protects His Wife. He keeps His Wife from harm.

The idea of Jesus having a Wife - is NOT symbolic. In some ways of course - it is symbolic. But many scriptures exist where Jesus compares the Kingdom, etc. to a Marriage and Wedding. Jesus is looking for a Wife. And He is going to have a Wife. One that has made herself Holy and Pure.

The first description of the Wife is found in the reference to the Church of *Philadelphia*. Whose greatest attribute - is LOVE. Many, many, many people who call themselves Christians; and who do actually know, and have some sort of relationship with Jesus - are sadly lacking in Love. Myself included. LOVE is one of the *basic* qualifications for the Bride or Wife . . . so you might wish to do yourself a favor - and REPENT for your lack of LOVE for one another . . .

The first description of the Wife for the Lamb is the church of Philadelphia. It is found in verse 3:7

Verse **3:7**

**3 x 7 = 21**

And Three chapters in Revelation - are given to *show who* the Bride is . . .

Chapter *Twenty One* is the *last* chapter giving the identity of the Wife of the Lamb.

The next *measurement* of the Bride is found in Chapter *Seven*. (The chapter we are discussing.)

A brief description of the Wife, and her *escape* from the great tribulation is given in Chapter *twelve*. **Twelve**, the number of final and total completeness. In chapter *twelve*, the Wife of the Lamb is seen absolutely complete. No measurements or qualifications for her marriage are reiterated.

The next description and reference to the Bride is found in Chapter *Fourteen* (which mostly discusses the Wife in marriage terms and language . . .)

And - chapter *fourteen* declares the Bride to be a Virgin at verse: **14:4**

And the final reference to the Bride or *Wife* - is found in Chapter *Twenty One*.

Some other minor references to the Wife do exist in Revelation. For example, (R 19:7) states that the time of the wedding of the Bride has come.

*Let us rejoice and be glad and give him glory! For the wedding of the Lamb has come, and his bride has made herself ready.* (R19:7)

And a few other verses exist as well - but these are not stating WHO the Bride is . . . They acknowledge the existence of the Bride - but do not declare *WHO* she is . . . The references we have looked at in R3, R14, & R21 are given so that you might have the opportunity to really start serving and OBEYING God and Jesus. So that you might see your absolutely immense calling in God - and conform yourself to Him - so that you - might be part of His Bride . . . It truly is - our choice. Just as salvation is a choice - so too - is being part of the Bride or the Wife of the Lamb.

Finally, just before we move on in Chapter 7 (the chapter we have been discussing) - please allow me to make one small other point . . .



All of these other scriptures which I have quoted - to show you that the Bride exists, and the **144,000** constitute the *Wife of the Lamb* - were given for YOUR benefit.

I *already* knew the **144,000** were part of the **Bride**. Totally and solely - from reading one *prophecy* and one book ONLY. *Revelation*. The prophecy which is Revelation.

The HOLY SPIRIT desperately desires to teach you. To instruct you. Personally. One on One. I have been reading and listening to Revelation virtually every day - since early 2004. It is now late 2010 (10-7-10) - and God is still teaching me and showing me things in this amazing Prophecy. But - I understood that Chapter Seven discussed the Bride - around 2005. I have learned much since then; and God has shown me how this all fits together - but ALL of my knowledge of this prophecy - comes ONLY from reading Revelation - and listening to the Holy Spirit. It does NOT come from researching Greek or Hebrew words; or from reading any books other than the book of *Revelation*.

It is just that - in a commentary - I am required to 'prove' almost everything which I state. So - I can't just say something . . . I have to 'back it up' - with various scriptures. The Holy Spirit has been teaching me the flow and layout of this prophecy - solely because I give Him the time to do so. And rather than confusing myself by reading various commentaries, or other books of the Bible - I have been doing one thing, and one thing only. READING Revelation.

I was absolutely amazed - by the various scriptures (from other books in the Bible) that existed to be cited - as I wrote this commentary - so that these truths (which God had shown me) could be proved in a more fundamental manner. I didn't know the majority of them . . . I truly have been taught Revelation by the Holy Spirit . . . And I would again BEG you, and PLEAD with you in the name of our wonderful Lord - Jesus Christ - to allow yourself to do the same!

Just READ this wonderful prophecy, over and over and over and over again . . . until they take your Bible away! Let God instruct you. And then you can teach me and others - even more about this wonderful prophecy and the words Jesus has given us - so that we can have PEACE - in a world that has none.

We now move on in chapter 7; and will focus just a little bit more on those who experience and go thru the great tribulation. Although these are not part of the Bride; they **persevered** and did not renounce Jesus. The time of great tribulation is so horrendous and terrible - that Jesus states that this distress and amount of trial and testing - would occur only once - in all of creation, and history.

*For then there will be **great distress, unequalled from the beginning of the world until now - and never to be equaled again.** If those days had **not been cut short**, no one would survive, but for the **sake of the elect those days will be shortened.*** (Matthew 24:21 - 22)

*because those will be **days of distress unequalled from the beginning, when God created the world, until now - and never to be equaled again.** If the Lord had not cut short those days, no one would survive. But for the **sake of the elect, whom he has chosen, he has shortened them.*** (Mark 13:19 - 20)

Chapter Seven goes from the **144,000**; to the multitude so **huge**, that it could not be counted. They come from every tribe, people, nation and language - and they hold **palm** branches (*signifying Victory*), and are wearing white robes; and they sing glorious songs of Praise to God and the Lamb. They declare that **Salvation** comes from God the Father, and God the Lamb. And then everyone falls down, and worships the totality of God. ((Worshipping the Father, the Lamb or Jesus, and the Holy Spirit (seven spirits before

His throne).

*From the throne came flashes of lightning, rumblings and peals of thunder. Before the throne, seven lamps were blazing* [G/K 4786 + G/K 2794] *πυρὸς καιόμεναι* (fire, flames + to light (a wick), keep burning). *These are the seven spirits of God.* (R4:5)

*After this I looked and there before me was a great multitude that no one could count, from every nation, tribe, people and language, standing before the throne and in front of the Lamb. They were wearing white robes and were holding palm branches in their hands. And they cried out in a loud voice: "Salvation belongs to our God, who sits on the throne, and to the Lamb."* (R7:9 - 10)

**Palm branches** indicate **victory**. Here, the indication and statement - is **victory** during the Great Tribulation. They were not deceived by Satan, they did not take the mark of the Beast; and they maintained *the Word of God* and their *testimony* for Jesus. (R6:9)

During the Feast of Tabernacles; Jesus entered Jerusalem. This was a **triumphal** entry, where the crowds were shouting out Praise to Him. They thought He would overthrow Rome, and make the Jews a great nation again. They were looking to Him as a King and future Ruler. Of course, He is all of that - just in a slightly different context . . . So - since **Palm branches signify Victory** - the crowds took palm branches with them - to meet and greet Him. The Jewish people were constantly looking for someone to liberate them from Rome. Which is one of the reasons why, after his resurrection; Jesus' disciples asked Him about His restoration of the Kingdom of Israel.

*The next day the great crowd that had come for the Feast heard that Jesus was on his way to Jerusalem. They took palm branches and went out to meet him, shouting, "Hosanna!" "Blessed is he who comes in the name of the Lord!" "Blessed is the King of Israel!"* (John 12:12 - 13)

*Then Jesus said to the chief priests, the officers of the temple guard, and the elders, who had come for him, "Am I leading a rebellion, that you have come with swords and clubs?"* (Luke 22:52)

*Pilate called together the chief priests, the rulers and the people, and said to them, "You brought me this man as one who was inciting the people to rebellion. I have examined him in your presence and have found no basis for your charges against him."* (Luke 23:13 - 14)

*So when they met together, they asked him, "Lord, are you at this time going to restore the kingdom to Israel?"* (Acts 1:6)

## [Gladiator

(Latin: "swordsmen," from *gladius*, "sword"), professional combatant in ancient Rome. The gladiators originally performed at Etruscan funerals, no doubt with intent to give the dead man armed attendants in the next world; hence the fights were usually to the death. At shows in Rome these exhibitions became wildly popular and increased in size from three pairs at the first known exhibition in 264 BC (at the funeral of a Brutus) to 300 pairs in the time of Julius Caesar (d. 44 BC). Hence the shows extended from one day to as many as a hundred, under the emperor Titus; while the emperor Trajan in his triumph (ad 107) had 5,000 pairs of gladiators. Shows were also given in other towns of the Roman Empire, as can be seen from the traces of amphitheatres.

There were various classes of gladiators, distinguished by their arms or modes of fighting. The *Samnites*

fought with the national weapons - a large oblong shield, a visor, a plumed helmet, and a short sword. The *Thracians* (“Thracians”) had a small round buckler and a dagger curved like a scythe . . .

The shows were announced several days before they took place by bills affixed to the walls of houses and public buildings; copies were also sold in the streets. These bills gave the names of the chief pairs of competitors, the date of the show, the name of the giver, and the different kinds of combats. The spectacle began with a procession of the gladiators through the arena . . . The **reward** of **Victory** consisted of **branches of Palm**, and *sometimes* of **money**. (Copyright © 1994-2002 Encyclopædia Britannica, Inc. [2002 Deluxe Edition CD-ROM; v2002.01.0002.01])

*All the angels were standing around the throne and around the elders and the four living creatures. They fell down on their faces before the throne and worshiped God, saying: “Amen! Praise and glory and wisdom and thanks and honor and power and strength be to our God for ever and ever. Amen!”* (R7:11 - 12)

The all important **Question** is asked - that we previously discussed. It is stated these came out of the great *tribulation* **θλίψεως** (*trouble, distress, oppression, tribulation*) and that they **washed** their robes and made them **white in the Blood** of the Lamb. And that they shall **rejoice**, and **never hunger or thirst again**; and that God *Himself* - will wipe every tear from their eyes . . . They will be led to the springs of living water which God and the Holy Spirit provides.

*Yet you have a few ὀλίγα (little, small, short, (pl.) few) people in Sardis who have not soiled their clothes. They will walk with me, dressed in white, for they are worthy. He who overcomes νικῶν (to overcome, overpower, to conquer, triumph) will, like them, be dressed in white. I will never blot out his name . . .* (R3:4 -5)

*Then one of the elders asked me, “These in white robes - who are they, and where did they come from?” I answered, “Sir, you know.” And he said, “These are they who have come out of the great μεγάλης (great; spatially large; of quantity or degree: loud, intense, violent; of time: long (time); of position: great, important) tribulation; they have washed their robes and made them white in the blood of the Lamb. Therefore, “they are before the throne of God and serve him day and night in his temple; and he who sits on the throne will spread his tent over them. Never again will they hunger; never again will they thirst. The sun will not beat upon them, nor any scorching heat. For the Lamb at the center of the throne will be their shepherd; he will lead ὁδηγήσει (to lead, guide; explain, instruct) them to springs of living water. And God will wipe away every tear from their eyes.”* (Rev 7:13 - 17)

## (Chapter 8)

*When he opened the seventh seal, there was silence in heaven for about half an hour. And I saw the seven angels who stand before God, and to them were given seven trumpets. Another angel, who had a golden censer, came and stood at the altar. He was given much incense to offer, with the prayers of all the saints, on the golden altar before the throne. The smoke of the incense, together with the prayers of the saints, went up before God from the angel’s hand. Then the angel took the censer, filled it with fire from the altar, and hurled it on the earth; and there came peals of thunder, rumblings, flashes of lightning and an earthquake.* (Rev 8:1 - 5)

The above verses seem mostly self - explanatory. First - the *seventh* seal is opened. This seal completes the *opening* of the scroll, and signifies divine completeness and finality. In Heaven - we have seen much shouting and many various sounds. Heaven has not been described as very quiet. We have actual lightning bolts, thunders, Praise, Creatures calling out, voices of thunder, songs of praise, music of Harps,

etc. Not very quiet.

Now - we have absolute silence. A person could hear a pin drop to the floor. Quiet, or SILENCE. This is because of what is about to take place. Even the 24 elders who - it was stated - NEVER stop shouting out praise - now these too, are quiet . . .

Mankind and Creation have several *major* events which have and will occur. These events may be briefly summarized as follows:

1. God CREATES the Earth, Sun, Moon, Stars; and Mankind. (Adam & Eve)
2. Adam disobeys God (sins); causing spiritual separation (Death) between God and Man.
3. Jesus or *Immanuel* Ἐμμανουήλ (God with us) was born, lived a sinless life (Always being obedient to the Father); died, and was resurrected. With his life - he purchased or *redeemed* us back to God.
4. The Anti-Christ will take human form; and be worshiped by the vast majority of mankind as God.
5. Jesus will destroy the Anti-Christ's Kingdom; and *Rules* all of mankind for 1,000 years.
6. Satan will be released from the abyss; takes human form (again) , and mankind (again) rejects God, and attacks the city which God loves (the Bride of the Lamb or the New Jerusalem.)
7. Everyone comes before the great white throne for judgement. Death is destroyed, and all pain, tears, and sorrow - cease to exist. God rules forever and ever.

In scripture - the ONLY time silence is ever mentioned as occurring in Heaven - *immediately* after that - we see the prayers of the saints being revealed before the altar of God and His throne.

These two events are significant.

What precisely were Jesus' words in regards to the time when the anti-Christ would be ruling?

*“So when you see standing in the holy place ‘the **abomination** that causes **desolation**,’ spoken of through the prophet Daniel - let the reader understand - then let those who are in Judea **flee** to the mountains. Let **no one** on the roof of his house go down to **take anything** out of the house. Let **no one** in the field go back to get **his cloak**. How **dreadful it will be** in those days for pregnant women and nursing mothers! Pray that your flight will not take place in winter or on the Sabbath. For then there will be **great distress**, **unequaled from the beginning of the world** until now- and **never to be equaled again**. If those days had not been cut short, no one would survive, but for the **sake of the elect those days will be shortened**.*

(Matthew 24:15 - 22)

Jesus describes the time of the anti-Christ's rule as a time of GREAT distress! Distress of such massive proportions that the entire creation has NEVER seen before; and will NEVER be subjected to or see again . . . What do individuals undergoing great and tremendous distress *do??* Typically, we fall onto our knees; and PRAY! We cry out to God for deliverance!

Chapter *Eight* opens up with the *amazing* statement that absolute and TOTAL silence occurs in Heaven.

Then we follow up this statement by referencing the prayers of the saints!

Silence is occurring in Heaven - because chapter *Eight* opens up with the anti-Christ starting his rule of 1,260 days. With this reign of great *deception* - also comes great persecution of the saints of God! And so the saints of God pray for strength and endurance. They pray to overcome the massive deceptions; and they pray not only for themselves - but they pray for others who have not yet taken the mark of the beast; but who are wavering; and not understanding the great time of distress which is occurring.

Incense has spiritual significance, and is described as being fragrant before God . . . And here we have the *prayers* of all the saints who are *criying out* in *distress* during the anti-Christ's massive persecution, deception and reign; *together* with much *incense* or a pleasing fragrance - going up in smoke before God (He is breathing in your fragrance, flavor, and the sweet perfume of your prayers) and the golden altar which is before His throne.

*But thanks be to God, who always leads us in **triumphal procession** in Christ and through us spreads everywhere the **fragrance** of the knowledge of him. For we are to **God** the **aroma of Christ** among those who are being saved and those who are perishing.* (2Corinthians 2:14 - 15)

*I have received full payment and even more; I am amply supplied, now that I have received from Epaphroditus the **gifts** you sent. They are a **fragrant offering**, an acceptable sacrifice, **pleasing to God**.* (Phillipians 4:18)

*I will accept you as **fragrant incense** when I bring you out from the nations and gather you from the countries where you have been scattered, and I will **show myself holy** among you in the sight of the nations.* (Ezekiel 20:41)

And John sees *seven* angels who stand before God. And with the opening of the *seventh* and final seal - these seven angels are given *seven trumpets*. (The last or *seventh* trumpet of these trumpets - is the last trumpet referenced in 1Corinthians 15:52) The *prayers* of *numerous distressed* saints are going up before God and His throne, and the trumpets which have been proclaimed in prophecy throughout all of history - are about to be used . . . Satan or the great dragon, has just been kicked out of Heaven (R12); and the anti-Christ (Satan incarnate) has just come into his Kingdom (R13); and so silence occurs in Heaven.

The first of many judgements from Heaven. These judgements are given for several different reasons.

1. To encourage men to repent, and turn back to the True, Holy, and absolute Sovereign God.
2. To harden men's hearts towards God, and cause them not to repent.
3. To give the anti-Christ greater ability to deceive.
4. Because men are worshiping the anti-Christ, and declaring him to be God; and not worshiping the one true, sovereign and Holy God.

Some of these four statements might seem contradictory. But consider Pharaoh, Egypt, and the Israelites:

*The LORD said to Moses, "When you return to Egypt, see that you perform before Pharaoh all the wonders I have given you the power to do. But I will harden his heart so that he will not let the people go.* (Exodus 4:21)



*But I will harden Pharaoh's heart, and though I multiply my miraculous signs and wonders in Egypt, he will not listen to you. Then I will lay my hand on Egypt and with mighty acts of judgment I will bring out my divisions, my people the Israelites.* (Exodus 7:3 - 4)

*And I will harden Pharaoh's heart, and he will pursue them. But I will gain glory for myself through Pharaoh and all his army, and the Egyptians will know that I am the LORD." . . .* (Exodus 14:4)

*Why, O LORD, do you make us wander from your ways and harden our hearts so we do not revere you?* (Isaiah 63:17)

*For the Scripture says to Pharaoh: "I raised you up for this very purpose, that I might display my power in you and that my name might be proclaimed in all the earth." Therefore God has mercy on whom he wants to have mercy, and he hardens whom he wants to harden.* (Romans 9:17 - 18)

*We have come to share in Christ **if** we hold **firmly** till the **end** the **confidence** we had at **first**. As has just been said: "Today, if you hear his voice, do not harden your hearts as you did in the rebellion." (Hebrews 3:14 - 15)*

Scripturally, judgements can be given to both draw individuals to repentance, and cause others to harden their hearts; while at the same time - increasing the Glory of God! So, too with these judgements. Satan will be using these judgements to draw attention to himself (R13); while God is using them to both harden those who refuse to believe - while at the same time - drawing a very few into true repentance.

*Then the angel took the censer, filled it with **fire** from the altar, and **hurled it on the earth**; and there came peals of thunder, rumblings, flashes of lightning and an earthquake.* (R8:5)

Weather changes, and earthquakes. Notice also, that here we have a *perspective* change. In Chapter *Eight* - we are going to be watching spiritual events - but see direct and immediate causes and links to those events on Earth.

**Fire** from the **altar of God** is hurled upon the Earth. Weather changes, and earthquakes result.

*Then the **seven angels** who had the **seven trumpets** prepared to sound them. The **first angel** sounded his **trumpet**, and there came **hail and fire mixed with blood**, and it was hurled down **upon the earth**. **A third of the earth was burned up, a third of the trees** were burned up, and all the **green grass** was burned up.* (Rev 8:6 - 7)

And, during the above time period, and spiritual activities going on - the anti-Christ is ruling; and the beast and the false prophet are deceiving. Deceiving Billions. In Chapter Eight - the anti-Christ is ruling. I will give more evidence of this shortly . . . These trumpet blasts and judgements are upon those who have not submitted to Jesus, and are facing the choice of receiving the mark of the beast. They do of course - affect the huge majority of believers who did not qualify to be part of the Bride, or the *Wife of the Lamb*.; and are experiencing the Great Tribulation.

*The **second angel** sounded his **trumpet**, and something like a **huge mountain, all ablaze**, was thrown into the sea. **A third of the sea turned into blood, a third of the living creatures in the sea died, and a third of the ships were destroyed.*** (Rev 8:8 - 9)

All of these verses in chapter *eight* are mostly self-explanatory. Here the second trumpet is played; and the ultimate result is one third of everything in or on the seas - is destroyed. Huge devastation of sea life;

and massive shipping, fishing, and commerce disruption. It is possible this trumpet blast only affects fishing boats, and the like . . . Those boats who are retrieving *food* from the waters or seas. That is possible. The focus is on the massive death coming to sea life. That is to cause food supply disruption to mankind. However, it is also entirely possible and likely; that when it states a *third of all the ships were destroyed* -that it means a third of all ships were destroyed. *Any* and all Ships. Fishing, shipping, oil tankers, pleasure, etc.

*The third angel sounded his trumpet, and a great star, blazing καιόμενος (to light (a wick), keep burning) like a torch, fell from the sky on a third of the rivers and on the springs of water - the name of the star is Wormwood. A third of the waters turned bitter, and many people died from the waters that had become bitter.* (Rev 8:10 - 11)

Here we have *fire* reigning down on earth; and *polluting drinking* water.. Probably some sort of numerous asteroids falling all over the place. Flaming, burning rocks. Affecting springs of water, and *numerous fresh water* rivers. *What* they are - is not really the focus. The *result* is the *destruction* of a huge portion of all the *potable water* supply.

*The fourth angel sounded his trumpet, and a third of the sun was struck, a third of the moon, and a third of the stars, so that ἵνα (a marker that shows purpose or result in order that, in order to, so that, then, it can focus on the introduction of a discourse or on the content itself) a third of them turned dark. A third of the day was without light, and also ὁμοίως (likewise, in the same way, similarly) a third of the night. As I watched, I heard an eagle that was flying in midair call out in a loud voice: "Woe! Woe! Woe to the inhabitants of the earth, because of the trumpet blasts about to be sounded by the other three angels!"* (Rev 8:12 - 13)

In scripture, the *sun* represents God, the Father. And the *moon*, which reflects the light of the sun, and is only visible because of the reflected light - represents God, the Son. And the *stars* which are cast broadly thru the heavens, and *star* differs from *star* in *splendor* (1Cor 15:41), and are too numerous to count - represent God, the Holy Spirit.

In these verses, God is *not* stating that He shakes Himself up. But, since He created all things, and thru Him all things were created; God is using the three major focal and centerpieces of the Heavens and His creation - to make a statement. The moon, stars, and the sun - also represent our *seasons*, and how the entire Universe functions and flows for our planet.

Verse 12 describes a MAJOR heavenly shakeup. The moon will still reflect light, and the sun will still give light. But verse *twelve*, describes a MAJOR and tremendous reorganization of the entire solar system, and the Universe. The purpose of this tremendous, (and very sudden) change is seen in the following: *so that a third of them turned dark. A third of the day was without light, and also a third of the night.*

We strike the heavens and the entire Universe - to cause 1/3 of them to *grow dark*? What does that mean? Well, the next words tell you . . .

*A third of the day was without light, and also a third of the night.*

If a catastrophic event happened, which somehow caused our sun to lose some light - what would we have?? Shorter daylight hours, and *longer* night hours. Our nights would be longer . . . But the *TOTAL hours* constituting an entire 24 hr 'day' would still be precisely the same.

However - here God strikes the heavens. He rearranges gravity, and the entire universe - so that not only are our **daylight** hours shorter - but so too - is the night!

In other words - God just **literally** - *shortened* the days. And He did so for one reason, and one reason only! For the sake of the **elect**! God has determined in his own mind, and for His own purposes, and reasons - that the **number of days** of this judgement and tribulation period - will be for a **specific length**. But the **deceptions** which are involved during this tribulation period are MASSIVE. And the consequences of God's judgements on the earth, against mankind who are not repenting - are huge . . . Consequently - **Jesus** stated that these days of **tribulation** would be *shortened* . . . And so here - during the tribulation period; when the anti-Christ is ruling, and deceiving all those *whose names have not been written in the book of Life from the creation of the world* - God *shortens* these days for the sake of the elect.

Our **Twenty-Four** hour day - just became a **Sixteen** hour day. Massive planetary shakeup.

*For then there will be **great distress, unequaled** from the beginning of the world until now- and **never to be equaled again**. If those days had not been **cut short**, no one would survive, but for the **sake of the elect** those **days will be shortened**.* (Matthew 24:21 - 22)

*Pray that this will not take place in winter, because those will be **days of distress unequaled** from the beginning, when God created the world, until now - and **never to be equaled again**. If the **Lord** had not cut short those days, no one would survive. But for the **sake of the elect**, whom he has chosen, he has **shortened them**.* (Mark 13:18 - 20)

Then we have an **Eagle** (a voice from God - remember God rescues on Eagle wings) calling out woe to the inhabitants of the earth. This might be a voice thundering directly from Heaven. It is probably more the case of all the numerous people who are remaining faithful to Jesus, and dying for Him - along with the two witnesses - giving testimony that you are **doomed** if you take the mark or worship the beast or his image; and that you should repent . . . Either way, or no matter - the spiritual statement of truth is: Even more **Tremendous Woe** and **Hurt** and **Judgements** - are **coming** upon the inhabitants of the Earth - with the remaining three trumpet blasts that are still to be sounded by the other three angels!

(Chapter 9)

*The **fifth** angel sounded his trumpet, and I saw a **star** that **had fallen** from the sky to the earth. The **star** was **given the key to the shaft of the Abyss**. When he opened the Abyss, **smoke** rose from it like the smoke from a **gigantic furnace**. The **sun and sky were darkened** by the **smoke** from the Abyss. And out of the smoke locusts came down upon the earth and were given power like that of scorpions of the earth. They were told **not to harm the grass** of the earth or **any plant or tree**, but only those people who **did not** have the **seal of God** on their foreheads. They were **not given power to kill** them, but **only to torture** them for **five months**. And the agony they suffered was like that of the sting of a scorpion when it strikes a man. During those days men will seek death, but will not find it; they will long to die, but death will elude them. The locusts looked like horses prepared for battle. On their heads they wore something like crowns of gold, and their faces resembled human faces. Their hair was like women's hair, and their teeth were like lions' teeth. They had breastplates like breastplates of iron, and the **sound of their wings** was like the thundering of **many horses and chariots** rushing into battle. They had tails and stings like scorpions, and in their tails they had **power to torment people for five months**. They had as king over them the angel of the Abyss, whose name in Hebrew is Abaddon, and in Greek, Apollyon. The first woe is past; two other*

*woes are yet to come.* (Rev 9:1 - 12)

These verses which open up chapter nine, are hard to interpret and understand. Not because of any failing of the Holy Spirit - but because of all the junk which has filled my poor head over the years . . .

I've never read "*The Late Great Planet Earth*" by Hal Lindsey. But I was born in 1955; so obviously I was alive during the book's immense popularity. I've heard many people comment on it - over the years. So, when I come to chapter nine - I do tend to think of Helicopters, Gunships, etc. I can easily see how a person might interpret these verses in such a manner.

However - I believe the torment being brought forth from the fifth trumpet - are from direct spiritual sources. Not from mankind. A couple of verses do exist in Revelation - which specifically identify judgements being brought forth, or delivered - by man. However, most of the judgements which are mentioned in Revelation - are stated to be almost directly from God. The judgement which opens up chapter nine - is described as being called forth by God; and God desires for it to occur; but God uses spiritual forces to accomplish the judgement.

Now, what if the delivery method of the judgements or torments being spoken of in chapter nine - what if those *are* Helicopters and military might?

Well, if that is the case - so be it. It doesn't change the focus of the prophecy; or where this prophecy given to us by Jesus - is headed. Doesn't change the focus at all, or in any way . . .

But John, who was on the Island of Patmos (a forced labor mining colony); when Jesus asked him to record this prophecy - was not stupid. He had an idea of tools, and what machines were . . . He knew what metal was . . .

In other words - John easily could have stated: "*And I saw some large man made tools; which were made of metal, and capable of flight. And people got into them . . .*"

But John makes no such or similar statement. Instead, with a prophecy which Jesus states is easily understood - by anyone who has an *ear to hear*; and is open to understanding by His servants - John makes the following statement: He states these are spiritual beings - doing harm to mankind.

Just before we come to these verses - we have *drinking water* supplies being destroyed; and the earth's orbit being changed . . . We go from a 24 hour day to a **16 hour** day.

And, right after the five month torment - we go immediately to the four angels who are *bound* at the great river Euphrates. These are spiritual beings - who disobeyed God a long time ago; and do not harbor good will toward mankind. That's *why* they are *bound*.

The previous judgements were caused by pure spiritual authority and actions. The judgements to follow are caused by pure spiritual authority and actions. It makes sense therefore - to believe that John actually stated what he saw, and that he was not confused by what he saw . . . And that in fact - what he saw - were demonic creatures being released upon the earth.

It might be slightly instructive to also note that when John *was* confused - he was asked another question!

*I saw that the woman was drunk with the blood of the saints, the blood of those who bore testimony to Jesus. When I saw her, I was greatly **astonished**. Then the angel said to me: “**Why** are you **astonished**? I will **explain** to you . . . (R17:6-7)*

Finally, if these are not demonic beings bringing destruction, but are members of a world military force - than their weapons of warfare are extremely selective. For the coming torments do not affect Christians, but only those who have rejected God. And the weapons do not kill. They only cause pain for 5 months. But no death. In fact, people long to die - but death eludes them. During this five month period - it would seem people cannot die . . . Our military are developing non-lethal weapons. Sound disruption waves; and microwave heat disruption weapons. These incapacitate an enemy. And I'm sure they are also developing types of non-lethal weapons - which have not been made public. But I don't believe they are developing weapons which target a person based on their religious beliefs . . . Any military weapon developed - even a non-lethal type - would not discriminate in its function - based on a persons religious beliefs. In fact - it would not discriminate against any person. It would affect any person within its sphere of influence.

*The **fifth** angel sounded his trumpet, and I saw a **star** that **had fallen** from the sky to the earth. The **star** was **given the key** to the **shaft of the Abyss**. (R9:1)*

*Have you come here to **torture us** before the **appointed** time?” Some distance from them a large herd of pigs was feeding. The demons **begged** Jesus, “**If you drive us out**, send us into the herd of pigs.” (Matthew 8:29 - 30)*

*What do you want with me, **Jesus**, Son of the Most **High God**? Swear to God that you won't **torture me!**” For Jesus had said to him, “Come out of this man, you evil spirit!” Then Jesus asked him, “What is your name?” “My name is Legion,” he replied, “for we are many.” And **he begged Jesus** again and again **not to send them out of the area**. (Mark 5:7 - 10)*

***Jesus** asked him, “What is your name?” “Legion,” he replied, because many demons had gone into him. And they **begged him repeatedly** not to order them to **go into the Abyss**. (Luke 8:30 - 31)*

*For if **God did not spare angels** when they sinned, but sent them to hell, putting them into **gloomy dungeons** to be held for **judgment**; (2Peter 2:4)*

An abyss exists, where demonic beings are being held. Being held for judgement. The 2<sup>nd</sup> Peter scripture just cited - could possibly indicate - *being held until they are temporarily released* - to provide **judgement** against mankind. The abyss is not a place where the fallen angels wish to live. They begged Jesus to not send them there. Being in the abyss is a form of Judgement; and Peter states that the **abyss is Hell**.

John sees a fallen angel or demon. The fall had taken place some time back . . . The star is obviously a spiritual entity - and not a meteor or asteroid or some other rock or mountain - since the star is a living being, which is given a key. The **key** to the shaft of the abyss.

When the demonic entity opens the Abyss - smoke pours forth from it like from a **gigantic furnace**. This smoke darkens the sun and the sky. This appears to be a type of physical smoke - which substantially obscures the daylight. It could be a heavy spiritual cloud - which is allowed to affect the daylight. In any event - out of the abyss, pour forth demonic beings - who only desire to kill and destroy mankind.

However, just like with Satan and Job - they are allowed to go only so far . . . They have three restrictions.



Those *three* restrictions are:

1. Not allowed to harm any type of plant (grass, tree, etc.)
2. Not allowed to touch or harm any person who has the seal of God on their foreheads. (This is the seal of salvation - granted by the Holy Spirit.)
3. Not allowed to kill anyone. Only to torment them for five months.

Angels when they appear before man, have generally terrified them. The power and authority which an angel possesses - have caused great men of God to faint in fear.

*I, Daniel, was the only one who saw the vision; the men with me did not see it, but such **terror** overwhelmed them that they fled and hid themselves. So I was left alone, gazing at this great vision; I had **no strength** left, my face turned **deathly pale** and I was **helpless**.* (Daniel 10:7 - 8)

*How can I, your servant, talk with you, my lord? My **strength** is gone and I can **hardly breathe**.* (Daniel 10:17)

Now these are demonic, evil beings - who have great power. Angels who serve God, cause men of God to faint and lose all of their strength. Demonic angles who have turned away from God and serve the destroyer (Satan) - these angels are also terrifying to look at . . . And they do not have your best interests at heart. They HATE you. So, these evil beings which John saw in this prophecy being given to him - these beings had faces, hair and teeth. They were deformed from their time in the abyss and their desire to relish in evil - and so they have tails and stings like scorpions. They are terrifying to gaze upon.

A five month period of torment is mentioned twice, and emphasized. They are allowed to torment for five months. *One Hundred and Fifty days*. (In Revelation prophecy - one month equals 30 days).

Satan is a deceiver. He deceives and cajoles mankind into worshiping him as God, and into taking the mark of the beast; and into worshiping the image which came to life. (R13) All of which is going on at this point in time. Chapter *thirteen* gives more details and a different perspective on how all of this came about - but it is occurring *here also* in Revelation. Same, exact time period.

Satan will *use these torments* - which he has control over - to encourage individuals to fully believe in him - as God. And so, the great deceiver, while telling people to worship him - is also tormenting them - for five months.

And in all of this - people are not allowed to die. At least the individuals who have been touched by the demonic angels from the abyss. These are not allowed to die, for the next five months. In Revelation - as we approach the end - and Jesus' ruling over ALL of creation - the spiritual touches more and more of our physical. In various verses throughout the Bible - God states He holds our life in His hands . . . and now the spiritual prevents physical death.

*This is what **God** the LORD says - he who created the heavens and stretched them out, who spread out the earth and all that comes out of it, who **gives breath** to its people, and **life** to those who walk on it . . .* (Isaiah 42:5)

*. . . fear the **LORD** your **God** as long as you live by **keeping all his decrees** and commands that I give you, and so that you may **enjoy long life**.* (Deuteronomy 6:2)

These demonic beings had authority to hurt mankind. They function within that authority. They were wearing crowns of gold.

*On their heads they wore something like crowns of gold . . . (R9:7)*

In today's modern world - we have forgotten that the spiritual actually exists. We have forgotten that the spiritual is much more powerful than the physical. What does the common spiritual phrase which we sing in song mean:

*But the weapons of our warfare are not carnal. They are not carnal; they are mighty, they are mighty . . .*

*The weapons we fight with are not the weapons of the world. On the contrary, they have divine power to demolish strongholds. (2Corinthians 10:4)*

*For the weapons of our warfare are not carnal, but mighty through God to the pulling down of strong holds . . . (2Corinthians 10:4 KJV)*

But today - these are just words mouthed in joyful tunes with no meaning or substance or true faith behind them. We no longer believe in demons inhabiting people, or in the spiritual controlling the physical. After all, we have technology, our cars, our heated homes, running water, and electricity! But we lack faith, and the understanding that the spiritual **rules** the physical. Jesus questioned if He would find faith when He returned . . . Today, with all of our physical needs provided for, and mankind delving deep into the very fundamental nature of atoms - we no longer have true faith; and we do not believe that the spiritual exists. In everything which we do - we look for the 'real' reason of why something happened - without considering that the 'real' reason - actually exists in the very foundation of the spiritual.

*. . . However, when the Son of Man comes, will he find faith on the earth?" (Luke 18:8)*

*Although they claimed to be wise, they became fools . . . (Romans 1:22)*

Men go to great lengths to deny the existence of God. And with our denial of God - we deny the spiritual. We deny that Satan exists and seeks to devour us . . . We deny that we are in a WAR; and we spend thousands and thousands of hours watching television, or going to the movies, or playing video games; or doing gardening - all without developing a pure and true relationship with the sovereign ruler - GOD.

Satan exists. The abyss exists. And sooner than we would like to think - terrible, terrible demonic beings are going to pour forth out of that abyss - and terrorize and torment millions of people - for five long months . . .

*"Skin for skin!" Satan replied. "A man will give all he has for his own life. But stretch out your hand and strike his flesh and bones, and he will surely curse you to your face." The LORD said to Satan, "Very well, then, he is in your hands; but you must spare his life." So Satan went out from the presence of the LORD and afflicted Job with painful sores from the soles of his feet to the top of his head. (Job 2:4 - 7)*

*They had as king over them the angel of the Abyss, whose name in Hebrew is Abaddon 'Αβαδδών, (Abaddon, "{destruction}") and in Greek, Apollyon 'Απολλύων (Apollyon, "{destroyer}"). (R9:11)*

*The thief comes only to steal and kill and destroy . . . (John 10:10)*

\*\*\*\*\*

*The first woe is past; two other woes are yet to come. The sixth angel sounded his trumpet, and I heard a voice coming from the horns of the golden altar that is before God. It said to the sixth angel who had the trumpet, "Release the four angels who are bound at the great river Euphrates." And the four angels who had been kept ready for this very hour and day and month and year were released to kill a third of mankind. The number of the mounted troops was two hundred million. I heard their number. The horses and riders I saw in my vision looked like this: Their breastplates were fiery red, dark blue, and yellow as sulfur. The heads of the horses resembled the heads of lions, and out of their mouths came fire, smoke and sulfur. A third of mankind was killed by the three plagues of fire, smoke and sulfur that came out of their mouths. The power of the horses was in their mouths and in their tails; for their tails were like snakes, having heads with which they inflict injury. The rest of mankind that were not killed by these plagues still did not repent of the work of their hands; they did not stop worshipping demons, and idols of gold, silver, bronze, stone and wood - idols that cannot see or hear or walk. Nor did they repent of their murders, their magic arts, their sexual immorality or their thefts. (Revelation 9:12 - 21)*

Two more woes or times of tremendous trouble - are still to come. With this trumpet blast - the four angels which we were briefly introduced to in chapter seven are brought back into our vision.

*After this I saw four angels standing at the four corners of the earth, holding back the four winds of the earth to prevent any wind from blowing on the land or on the sea or on any tree. . . . in a loud voice to the four angels who had been given power to harm the land and the sea: "Do not harm the land or the sea or the trees until . . . (Rev 7:1 - 3)*

These angels are BOUND. They have been BOUND for a long time. They are now allowed to be released. The reason they were bound up - is that they hate mankind. They wish only to harm mankind. So, now a time of tremendous judgement has come upon the earth. God states to release these four angels. Just like the demonic beings which were locked up, and contained in the abyss - these four angels are now released. They desire only to harm and destroy mankind. So that is what they do . . . They KILL one third of all mankind.

*And the four angels who had been kept ready for this very hour and day and month and year were released to kill a third of mankind. (R9:15)*

If you stop all wind on the earth - (which is what it was previously stated they would do . . .) the amount of pollution would increase exponentially. Certain areas of the earth would become very hot, and various fires would result. Other areas would have air that became very difficult to breathe, and would stink and be filled with smoke and awful smells, and poisonous gases. The results of no wind movement whatsoever - on the earth - would be catastrophic. Millions of people would die. Just as stated above. The air which we breath would become thick with smoke, fire and sulfur. Exactly as stated above. And all from the result of zero refreshing breezes across the earth.

These four angels are also stated to have troops. They were probably not the only demonic angels bound up; and held from causing massive destruction. So, just as the demonic beings being released from the abyss - with the opening of the abyss - and it was stated that their king was the 'destroyer'; so too - these four angels are probably 'king' or the head of a huge group of demonic beings desiring only one result. The death of mankind. But all of these demonic beings - submit to, and obey Satan - totally and fully.

So, the four angels have troops of demonic angels - who are all going out to create destruction. The word 'four' could be indicating four groups of demonic, evil beings. Just as Jesus stated that if He requested - God would at once put more than twelve legions of angels at His disposal.

*Do you think I cannot call on my Father, and he will at once put at my disposal more than twelve legions of angels?* (Matthew 26:53)

So we have precisely four angels (obeying Satan and his orders) - or four large groupings of angels - constituting troops - all of whom have only one goal, and one desire. The utter destruction of mankind. Now, I believe this is accomplished by the stopping of ALL refreshing wind and breezes. You would still have hot smoke swirling about - creating toxic 'breezes'; you would still experience the results of massive pollution. In fact - without any basic air movement, and cleansing of our breathable air - the very air itself - would start to run out of oxygen. The air would become extremely toxic . . . and millions would die. The stated number of resultant death - before this plague is called off - is ONE THIRD of all of mankind. Satan will control the weather; and start suffocating people who do not submit to him . . .

Some have speculated that these two hundred million mounted troops - are people or military forces going out to bring about massive destruction and death. Our military weapons generally cause lots of fire, and noxious gases . . .

I will not state emphatically - that these are not people going out into battle - in war machines. Could be. Does it really matter?? The leader of these troops - are four angels submitted to Satan. Spiritual, demonic leaders. Four angels who were *bound up* - to hold them until it was time for them to release the destruction they desire to see inflicted upon mankind. From what was stated previously with regards to these four angels or four large groups of demonic beings - that they would stop all air movement on the earth - one can easily see that the result of this action - would be massive, massive death. And smoke, fire, and acrid pollution. So, since all of the previous seals have resulted in judgements caused by spiritual forces - I see no real reason to believe this last seal - is any different. But truly - it does not affect the result; and does not affect the flow and layout of this glorious prophecy which we call Revelation - which Jesus Christ Himself gave us - so that we can know and understand - what is going to take place!

*“ ‘But I know where you stay and when you come and go and how you rage against me. Because you rage against me and your insolence has reached my ears, I will put my hook in your nose and my bit in your mouth, and I will make you return by the way you came.’* (2Kings 19:27 - 28)

*The LORD spoke to Manasseh and his people, but they paid no attention. So the LORD brought against them the army commanders of the king of Assyria, who took Manasseh prisoner, put a hook in his nose, bound him with bronze shackles and took him to Babylon.* (2Chronicles 33:10 - 11)

God is completely capable of using mankind's armies - to carry out His judgements against us. God is also fully capable of using solely spiritual forces - either Godly or demonic - to carry out His judgements against us. God is fully capable of carrying out His judgements against mankind - by Himself alone! So, it is our disbelief in the spiritual which causes us to 'look' for *what is really going on* . . . And generally when we look for what is *really* going on - we miss the truth. Especially with the *Revelation* prophecy - which has been declared to be OPEN to understanding.

The truth is - this 2<sup>nd</sup> woe is MASSIVE death! It is caused by spiritual forces. Whether those forces are all 100% evil spiritual beings - or they are leading military forces - it doesn't change the result or the focus

of the prophecy. Because of the introduction of these angels in Chapter seven; and the subsequent true results if all refreshing air movement and breezes were stopped - and because Revelation is a fairly direct prophecy when one takes the time to read it over and over; and to allow oneself to become familiar with the flow; and where God repeats the prophecy - and states the exact same events from a different spiritual perspective - for those reasons - I believe and understand these to be entirely spiritual forces bent on the destruction of mankind. But as you can see - it doesn't really matter. One third of mankind will be killed. The spiritual focus provides more emphasis on God, and the judgements which He is in fact bringing upon the earth - because of man's direct lack of repentance.

*The rest of mankind that were not killed by these plagues still did **not repent** of the work of their hands; they did not **stop worshiping demons**, and idols of gold, silver, bronze, stone and wood - idols that cannot see or hear or walk. Nor did they **repent** of their **murders**, their **magic arts**, their **sexual immorality** or **their thefts**. (Revelation 9:20 - 21)*

Here in the US; we state: "*We don't worship idols.*" But we do . . . How many hours did you spend in prayer and communion with God yesterday? How many hours did you spend watching television? The internet? Video Games? Gardening? Your iPod? Or hundreds of other stuff? God is not an almighty bug smasher; who does not wish for you to enjoy life, and celebrate His creation! But - in the US; we have more idols than most of the rest of the world! We even worship the Bible - substituting searching out God's word in scriptures - and regaling ourselves with the truths of what great men of God accomplished hundreds of years ago - rather than **us** learning to HEAR GOD; and than DO what God says . . . and accomplish great things of God for ourselves and for Him! Scripture is static. What are we doing for God today! He is the same yesterday, today, and forever. But you believe that He only wanted Peter and Paul to work for Him; and not you . . . and that today it is impossible to Hear Him! Well, it is virtually impossible to Hear Him - as long as we keep immersing ourselves in our own pleasures, lusts, and filth such as television! Do you know that there is NOTHING - *absolutely* NOTHING 'good' on television? If you are not saved - I suppose coming across a Christian broadcast - might help you repent and turn to God. But just because God has allowed a tenuous escape ladder in the midst of absolute depravity - is really not an excuse to justify spending hundreds of hours immersed in that depravity. And just because this wicked time stealer; & relationship destroyer - gives a tiniest bit of hope to individuals who are crippled and have no way to leave the home - does not justify the wickedness which is television.

If we were to get rid of our televisions - we might actually be ministering to the crippled. And since we then could have a deeper, and more pure, and intimate relationship with God - they might not be crippled anymore . . . what an absolute WASTE television is . . . and a deceiver! And numerous other 'things' which we waste our time and pleasures on!

*"No servant can serve **two masters**. Either he will hate the one and love the other, or he will be devoted to the one and despise the other. You **cannot serve both God and Money**." (Luke 16:13)*

*No **good tree** bears **bad fruit**, nor does a **bad tree** bear **good fruit**. Each tree is recognized by its own fruit. . . . (Luke 6:43 - 44)*

(Chapter 10)

*Then I saw another **mighty** angel coming down from heaven. He was **robed** in a **cloud**, with a **rainbow** above his head; his **face** was **like the sun** (R1:16), and his **legs** were **like fiery pillars**. He was holding a **little scroll**, which **lay open** in his hand. He planted his right foot on the sea and his left foot on the land, and*



he gave **a loud shout** like the roar of a **lion**. When **he shouted**, the voices of the **seven thunders spoke**. And when the seven thunders spoke, I was about to write; but I heard a voice from heaven say, "Seal up what the seven thunders have said and do not write it down." Then the angel I had seen standing on the sea and on the land raised his right hand to heaven. And he swore by him who lives for ever and ever, who created the heavens and all that is in them, the earth and all that is in it, and the sea and all that is in it, and said, "There will be no more delay! But in the days when the seventh angel is about to sound his trumpet, the mystery of God will be accomplished, just as he announced to his servants the prophets." Then the voice that I had heard from heaven spoke to me once more: "Go, take the scroll that lies open in the hand of the angel who is standing on the sea and on the land." So I went to the angel and asked him to give me the little scroll. He said to me, "Take it and eat it. It will turn your stomach sour, but in your mouth it will be as sweet as honey." I took the little scroll from the angel's hand and ate it. It tasted as sweet as honey in my mouth, but when I had eaten it, my stomach turned sour. Then I was told, "You must prophesy again about many peoples, nations, languages and kings." (Rev 10:1 - 11)

These are some hard verses to totally understand. I have the major gist of it; but on one point - I'm not totally sure where the compass needle rests.

Let us cover a few plot points, which are easily understood.

So **Jacob** was left alone, and a **man** wrestled with him till daybreak. When the **man** saw that he could not overpower him, he touched the socket of Jacob's hip . . . "I will not let you go **unless you bless me**." . . . Then he **blessed him** there. So Jacob called the place **Peniel**, saying, "It is because **I saw God face to face**, and yet my life was spared." (Genesis 32:24 - 30 edited)

The **mighty angel** is **Jesus Christ**. The lamb of God, King of Kings, Lord of Lords. For those who would state that this is not the Lamb of God - in **whose hand** was the **scroll** last seen??

. . . "Do not weep! See, the **Lion of the tribe of Judah**, the Root of David, has triumphed. **He** is able to **open the scroll** and its **seven seals**." (R5:5)

. . . "**You are worthy to take the scroll** and to **open its seals**, because you were **slain**, and with **your blood** you purchased men for God from every tribe and language and people and nation. (R5:9)

. . . "**Worthy is the Lamb**, who was slain, to **receive power** and **wealth** and wisdom and strength and **honor and glory and praise!**" (R5:12)

I watched as the **Lamb opened** the first of the seven seals. . . . (R6:1)

No one, in Heaven or on the earth; or even under the earth - was worthy to take the scroll.

. . . "Who is worthy to break the seals and open the scroll?" But **no one** in heaven or on earth or under the earth could **open** the scroll or **even look** inside it. (R5:2-3)

Then, we see the Lamb of God, taking the scroll, and opening it up. He was declared worthy to not only **LOOK** at the scroll; to not only **HOLD** the scroll; but to **OPEN** the scroll!

So, here the **scroll** is seen again. It is the next time the scroll is seen, after Jesus opened the seals in chapter six. This is such an important document. Only **ONE** person who has ever existed was found

worthy to even LOOK at the scroll. So, now we see the scroll again - it is lying *OPEN* in the *Hand* of a “mighty angel.” That ‘angel’ is Christ. Christ is referred to with many, many names and titles. He is the *root of David*; the *Lion of the Tribe of Judah*; *King of Kings*; the *Lamb who was Slain*; *Alpha and Omega*; *First and the Last*; *Son of Man*; *King of the Jews* . . . etc.

Here - Jesus is a *mighty angel*. The surrounding scriptures and verses support this ‘angel’ as being Jesus. So does the flow of this prophecy, and why Jesus is seen again - here in chapter ten.